



MATHEMATICAL MODELING OF BLOOD FLOW AND MASS TRANSFER  
IN THE HUMAN CARDIOVASCULAR SYSTEM

Luíza Wanderley Diniz

Dissertação de Mestrado apresentada ao Programa de Pós-graduação em Engenharia Química, COPPE, da Universidade Federal do Rio de Janeiro, como parte dos requisitos necessários à obtenção do título de Mestre em Engenharia Química.

Orientador: Argimiro Resende Secchi

Rio de Janeiro  
Fevereiro de 2019

MATHEMATICAL MODELING OF BLOOD FLOW AND MASS TRANSFER  
IN THE HUMAN CARDIOVASCULAR SYSTEM

Luíza Wanderley Diniz

DISSERTAÇÃO SUBMETIDA AO CORPO DOCENTE DO INSTITUTO ALBERTO LUIZ COIMBRA DE PÓS-GRADUAÇÃO E PESQUISA DE ENGENHARIA (COPPE) DA UNIVERSIDADE FEDERAL DO RIO DE JANEIRO COMO PARTE DOS REQUISITOS NECESSÁRIOS PARA A OBTENÇÃO DO GRAU DE MESTRE EM CIÊNCIAS EM ENGENHARIA QUÍMICA.

Examinada por:

---

Prof. Argimiro Resende Secchi, D.Sc.

---

Prof. Príamo Albuquerque Melo Jr., D.Sc.

---

Profa. Heloísa Lajas Sanches Fernandes, D.Sc.

---

Prof. Pablo Javier Blanco, D.Sc.

RIO DE JANEIRO, RJ – BRASIL  
FEVEREIRO DE 2019

Diniz, Luíza Wanderley

Mathematical modeling of blood flow and mass transfer in the human cardiovascular system/Luíza Wanderley Diniz. – Rio de Janeiro: UFRJ/COPPE, 2019. XIV, 57 p.: il.; 29,7cm.

Orientador: Argimiro Resende Secchi

Dissertação (mestrado) – UFRJ/COPPE/Programa de Engenharia Química, 2019.

Referências Bibliográficas: p. 53 – 57.

1. Mass transfer. 2. 0D model. 3. Cardiovascular system. 4. Process Simulator. 5. EMSO. 6. Physiological Based Pharmacokinetics. 7. PBPK. I. Secchi, Argimiro Resende. II. Universidade Federal do Rio de Janeiro, COPPE, Programa de Engenharia Química. III. Título.

*Para vovô Glauco*

# Acknowledgements

Agradeço à COPPE e à UFRJ, e principalmente ao PEQ. A todos que o compõem, desde as Roses da limpeza com sorrisos sempre abertos, a Luciana, Vera e Luan, que sempre me dispensaram muito carinho.

Gostaria de dirigir um agradecimento especial ao professor Pablo Javier, que muito solícitamente me permitiu usar suas figuras nesta dissertação;

Quanto a minha família, lembro-me da ocasião das festividades da formatura de graduação, quando me foi incumbido o papel de fazer o texto para os agradecimentos às famílias. Recordo-me de me perder nas palavras pensando em como agradecer a todos aqueles que carregam um pedaço do coração da gente. Percebi como era difícil transformar em palavras a importância de tais pessoas naquele momento, nenhum agradecimento recitado iria ser suficiente para demonstrar a nossa gratidão. Então, repito a única coisa com mais significado que pude encontrar em um dicionário naquele dia, quando pude dizer a minha família: os amo. Aos meus pais, minha irmã, meus avós, primos, tios e Áureo: os amo.

E realmente, o vocabulário não é tão extenso para ser possível agradecer aos amigos que fiz no PEQ, por tudo que aprendi, pelos cafés da tarde e longas conversas, além de todo o carinho e suporte. Sei que me ajudaram a ser uma pessoa melhor que a que chegou aqui.

Por último, a todos meus mestres do PEQ, em especial aos meus orientadores, Prof. Argimiro e Prof. Heloísa, dos quais as salas não eram meros escritórios, mas um divã e um lugar seguro. Estes mestres com quem sempre pude contar e que com muito carinho (e alguns puxões de orelha) me guiaram e me apoiaram (não só na pesquisa), que se tornaram modelos, mas, principalmente, amigos. A eles, toda a minha gratidão e admiração.

E a toda esta nova família que ganhei: os amo. Hoje tem sentido para mim a famosa frase de Bernardo de Chartres "se vi mais longe, foi por estar sobre o ombro de gigantes". A todos os gigantes que fizeram esta pequena anã vislumbrar novos horizontes: **muito obrigada.**

Resumo da Dissertação apresentada à COPPE/UFRJ como parte dos requisitos necessários para a obtenção do grau de Mestre em Ciências (M.Sc.)

## MODELAGEM MATEMÁTICA DE FLUXO SANGUÍNEO E TRANSFERÊNCIA DE MASSA NO SISTEMA CARDIOVASCULAR HUMANO

Luíza Wanderley Diniz

Fevereiro/2019

Orientador: Argimiro Resende Secchi

Programa: Engenharia Química

A utilização dos conceitos de fenômenos de transporte aliada à prática médica impacta positivamente a compreensão de fenômenos fisiológicos, auxiliando médicos em seus diagnósticos e fornecendo ferramentas para melhorias nos tratamentos. Caracterizar um sistema cardiovascular do ponto de vista da mecânica dos fluidos e do transporte de massa é uma estratégia eficiente e alternativa, podendo reduzir o número de intervenções cirúrgicas em um determinado paciente, aumentar a eficácia de tratamentos e a assertividade de diagnósticos. No presente estudo, é utilizado um modelo macroscópico multicompartimentos, que consiste em uma simplificação onde não são consideradas as variáveis espaciais, sendo o sistema variante apenas no tempo. Inicialmente, um modelo macroscópico 0D multicompartimentos é aplicado para a simular o sistema cardiovascular a fim de checar a implementação do modelo e a aplicabilidade do EMSO (*Environment for Modelling, Simulation and Optimization*) em uma simulação biológica. E em seguida, é inserido no sistema um modelo de farmacocinética baseado na fisiologia (PBPK). Os parâmetros necessários foram obtidos da literatura. Os resultados apresentados são qualitativos e satisfatórios, reproduzindo resultados reportados na literatura. Com isto, pretendemos estudar os aspectos governantes da disposição de fármacos no corpo, monitorando 3 variáveis: pressão, vazão e concentração. Os resultados da checagem são satisfatórios qualitativamente, mas não reproduzem os valores (quantitativo) da literatura, devido ao conjunto de condições iniciais. Os resultados obtidos são representativos para os perfis de variação no tempo da concentração de fármaco em diversos vasos e em tecidos (rins e fígado).

Abstract of Dissertation presented to COPPE/UFRJ as a partial fulfillment of the requirements for the degree of Master of Science (M.Sc.)

MATHEMATICAL MODELING OF BLOOD FLOW AND MASS TRANSFER  
IN THE HUMAN CARDIOVASCULAR SYSTEM

Luíza Wanderley Diniz

February/2019

Advisor: Argimiro Resende Secchi

Department: Chemical Engineering

The application of transport phenomena concepts combined with medical practice has a positive effect in physiological phenomena comprehension, aiding medical professionals with diagnosis and providing tools to improve treatments. To describe a cardiovascular system from a mechanical and mass transport point-of-view is an effective strategy that can reduce the number of surgical interventions, increase the efficiency of treatments and diagnosis precision. In this study is presented a new approach, from a chemical process point-of-view, for modeling the cardiovascular system. In order to implement and simulate the models the open-source process simulator software EMSO was used. Initially a compartmental macroscopic model (0D) is applied without any component balance. This model is a simplification where space variables are not considered rendering the system only time-variant. This stage was intended to first validate the using of EMSO (Environment for Modelling, Simulation and Optimization) for a biological simulation. Afterwards, the multicompartimental physiological based pharmacokinetics model (PBPK) was implemented in order to simulate the drug distribution in the system. The system was divided into several compartments where physiological properties can be considered constants. All parameters were obtained from literature. Qualitative results are presented. The main goal is to study drug disposition in the body by monitoring pressure, flow and concentration. The results for the model implementation checking (using EMSO) were satisfactory qualitatively, but did not reproduce the literature quantitatively due to the initial conditions. Representative profiles for the variation in time of the concentration of chemical in blood in several vessels and in tissues (kidney and liver) were obtained.

# Contents

<b>List of Figures</b>	<b>x</b>
<b>List of Tables</b>	<b>xii</b>
<b>List of Symbols</b>	<b>xiii</b>
<b>List of Abbreviations and Glossary</b>	<b>xiv</b>
<b>1 Introduction</b>	<b>1</b>
<b>2 Literature Review</b>	<b>4</b>
2.1 Cardiovascular System . . . . .	4
2.2 Mathematical modelling of the cardiovascular system . . . . .	7
2.2.1 The 0D Resistive-Compliant model . . . . .	9
2.2.2 The 0D compartmental models . . . . .	11
2.3 Pharmacokinetics . . . . .	13
2.3.1 Initial Concepts . . . . .	14
2.3.2 Pharmacokinetics models . . . . .	17
2.4 EMSO Simulator . . . . .	20
<b>3 Methodology</b>	<b>25</b>
3.1 The closed-loop macroscopic model in a cardiovascular system framework . . . . .	25
3.1.1 Heart chambers . . . . .	26
3.1.2 Heart valves . . . . .	29
3.1.3 Large vessels . . . . .	30
3.1.4 Microcirculation . . . . .	30
3.1.5 Parameters and initial conditions . . . . .	31
3.2 Pharmacokinetics in a process simulator . . . . .	31
3.2.1 Mass transfer model . . . . .	31
3.2.2 Parameters . . . . .	36
3.3 EMSO and machine setup . . . . .	36



<b>4</b>	<b>Results and Discussion</b>	<b>38</b>
4.1	Model implementation checking (without mass transfer) . . . . .	38
4.2	PBPK results . . . . .	42
<b>5</b>	<b>Conclusions and Suggestions</b>	<b>50</b>
5.1	Suggestions for future work . . . . .	51
	<b>Bibliography</b>	<b>53</b>

# List of Figures

2.1	CardioVascular system and its vessels . . . . .	5
2.2	Heart and its structures . . . . .	6
2.3	Vein and its structures . . . . .	7
2.4	Resistive circuit with switch. . . . .	10
2.5	Capacitive-resistive circuit with switch. . . . .	10
2.6	Number of publications per year just for studies with the key words "pharmacokinetics", "model" and "PBPK". . . . .	14
2.7	Illustration examples of drug administrations via enteral, parenteral and other routes. . . . .	16
2.8	Pharmacokinetics models: one and multi-compartmental . . . . .	19
2.9	Physiologic Based Pharmacokinetics model (PBPK) . . . . .	21
2.10	Studies involving the EMSO simulator since 2003 . . . . .	22
2.11	EMSO applications in simulations on different fields . . . . .	22
2.12	Example of model implementation in EMSO. . . . .	23
2.13	Example of "Device" declaring in EMSO flowsheet. . . . .	24
2.14	Example of "Connections" declaring in EMSO flowsheet. . . . .	24
3.1	Image of a human and its main blood vessels . . . . .	27
3.2	Flowchart of the cardiovascular system from a process engineering point-of-view. . . . .	28
3.3	Flowchart of the cardiovascular system with administration route and withdraw of a drug. . . . .	34
4.1	Comparison between literature and obtained results $P$ vs. $t$ for 15 cycles . . . . .	39
4.2	Comparison between literature and obtained results $P$ vs. $t$ for right heart . . . . .	40
4.3	Comparison between literature and obtained results $Q$ vs. $t$ for heart valves . . . . .	41
4.4	Comparison between literature and obtained results $P$ vs. $t$ for various sites . . . . .	42

4.5	Comparison between literature and obtained results $E_t$ vs. $t$ . . . . .	43
4.6	Comparison between literature and obtained results $P$ vs. $V$ heart chambers . . . . .	44
4.7	Comparison between literature and obtained results $V$ vs. time for heart chambers . . . . .	45
4.8	$X$ vs. $t$ results for the injection site . . . . .	46
4.9	$X$ vs. $t$ results for the microcirculation . . . . .	46
4.10	$X$ vs. $t$ results at the tissue elimination and return to the blood stream . . . . .	47
4.11	$X$ vs. $t$ results at the tissue elimination and return to the blood stream . . . . .	49
5.1	Suggestions for future works . . . . .	52

# List of Tables

2.1	CRM's underlying analogies. . . . .	10
3.1	Compartmentalization of the system network. . . . .	26
3.2	Parameters values for heart chambers. . . . .	31
3.3	Parameters values for heart valves. . . . .	31
3.4	Parameters values for veins and venules. . . . .	32
3.5	Parameters values for other vessels. . . . .	32
3.6	Initial conditions of the system. . . . .	33
3.7	Parameters for elimination at the tissues. . . . .	36
3.8	Initial volume parameter for blood vessels. . . . .	36
3.9	Hardware and Software configurations. . . . .	37

# List of Symbols

$C$	Compliance of a tissue (vessel), p. 31
$Cl$	Plasma Clearance, p. 36
$F$	Bioavailability, p. 36
$L$	Inductance of a tissue (vessel), p. 31
$P_{in}$	Blood pressure inlet of a compartment (mmHg), p. 31
$P_{out}$	Blood pressure outlet of a compartment (mmHg), p. 31
$Q_k$	Blood perfusion in kidney, p. 36
$Q_l$	Blood perfusion in liver, p. 36
$Q_{in}$	Blood flow inlet of a compartment (mL/s), p. 31
$Q_{out}$	Blood flow outlet of a compartment (mL/s), p. 31
$R$	Resistance of a tissue (vessel), p. 31
$V$	Volume, p. 36
$V_d$	Volume of Distribution, p. 36
$X$	concentration of a drug in the body, p. 33
$\beta$	Partition Coefficient, p. 36
$t_{\frac{1}{2}}$	Plasma half-life of drug, p. 36

# List of Abbreviations and Glossary

Absorption	Drug transport from an external source to the bloodstream, p. 14
DAE	Differential-Algebraic Equations, p. 20
Distribution	Drug transport from the bloodstream to the tissue, p. 15
EMSO	Environment for Modelling, Simulation and Optimisation, p. 20
IV	Intravenous, p. 16
PBPK	Physiologically Based Pharmacokinetic model, p. 18
Perfusion	Blood (or linfatic) flow from vessels to tissues, p. 15
Xenobiotic	Chemical substance found within an organism that is not naturally produced or expected to be present within the organism, p. 14

# Chapter 1

## Introduction

Can an engineer and/or a computer scientist help a physician's diagnostic? More important, how does it impact the prognostic of the patient?

The answer for the first question is well known: yes, they can. That is proved by a great deal of models that address physiological systems and its diseases. And that is not new for the cardiovascular system. Computational models used for planning surgeries and treatment courses already exists, as well as those that try to understand how a stenosis or a artherosclerosis affect the blood flow (KELM *et al.*, 2017; KÖPPL *et al.*, 2018; KUNG *et al.*, 2014; VAN BAKEL *et al.*, 2018). The problem is in the gap between the two specialties: neither the physician can understand the value of a computational method nor the engineer has sufficient physiological knowledge to assess the problems the right way (HUBERTS *et al.*, 2017). Therefore, there is a collection of good models that do not develop to clinical phase. Fortunately, this appears to be changing.

Nonetheless, it seems that the major bottleneck faced by scientists when developing their models is parameter estimation, after all it is not that simple to get measurements from a living organism. Aside from the fact that many of the measurements are invasive, the complex anatomical configuration, measurements synchronization and limited precision are problems that need overcoming.

It is important to bear in mind that every living system is unique and have its own peculiarities, i.e., that is no single one exactly equal to another. So, when can a general model or a patient-specific model be used? For HUBERTS *et al.* (2017) choose the model complexity is a challenge:

*“On the one hand, a model cannot be too simple as it will not capture the relevant physics and physiology, while on the other hand, the quality of a complex model (certainty in simulation outcomes) is difficult to assess since the high number of degrees of freedom make it possible to produce almost any desired behavior with often plausible parameter values”.*

Therefore, if the goal is to assess the matter in the best way when facing the challenge of choosing a model, then it must be adopted the one that has a positive impact in the patient’s prognostic.

According to WESTERHOF *et al.* (2009): "Models are a simplification of reality which help to understand function". From simple open-loop two-element windkessel (FRANK, 1899), to a highly sophisticated geometry 3D model, the ones regarding the cardiovascular system are broadly used.

The present study uses a multi-compartmental closed-loop macroscopic model to predict the flow and pressure, along with mass transfer models, in order to understand the distribution of drugs around the cardiovascular system. Macroscopic (or 0D) models are very common regarding cardiovascular systems and the literature is vast. Sadly that is not true for the mass transfer models: there is a gap in studies concerning this matter.

Hence, the main question that this study aims to answer is: “how does a drug is delivered through the cardiovascular system?”. And most importantly: “is it possible to assess the drug transportation in cardiovascular systems issue portraying it as a chemical process?”

In order to answer those questions in a more didactical approach, this thesis was divided as following: in each chapter, first there is a discussion of cardiovascular systems and its modelling only to introduce pharmacokinetics/pharmacodynamics later. That deliberated sectioning also has a role in better introducing the processes simulator EMSO, employed for the study, first validate its results with the literature. Afterwards, it is introduced the underlying concepts of pharmacokinetics and some theory on its models and the beforehand validated EMSO results are used and include a pharmacokinetic model to simulate the drug delivery in the system and present its results.

Therefore, the main objectives of this study are the following:

- To include mass balance and mass transfer model to existing vascular models in order to account for the drug distribution in the body;
- To investigate aspects of the drug transportation through the cardiovascular system.

The specific objectives are:



- To apply a closed-loop macroscopic model to predict pressure and flow rate in the cardiovascular system of a healthy (generic) person;
- To formulate a mass transfer and balance model;
- To present a new assessment of the system as a chemical process;
- To employ a process simulation tool (EMSO) to simulate the system;

# Chapter 2

## Literature Review

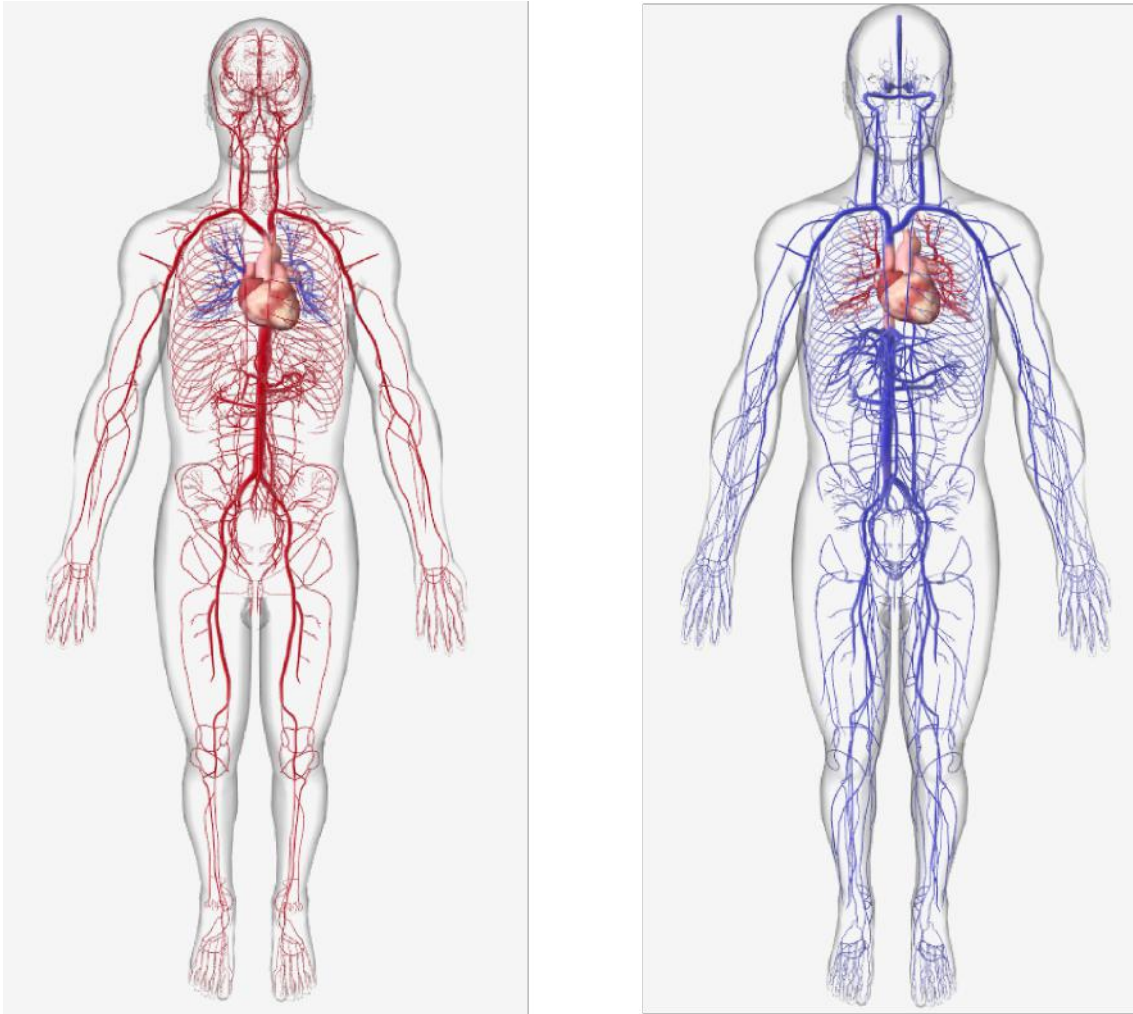
The Cardiovascular System and models background

### 2.1 Cardiovascular System

In order to fully assess the problem, it is important to understand how an living system works. To illustrate, Figure 2.1 shows the body arteries (in red - with exception from the pulmonary arteries) and body veins (in blue - with exception from the pulmonary veins).

To begin to explain the characteristics of a human cardiovascular system, first there is an obvious statement: it pulsates; and the heart is the one responsible for maintaining this pulsation, by contracting and relaxing at a cadenced way. It is composed of four chambers, two atria and two ventricles, and four valves. The contraction of the heart chambers is called systole and the relaxation, diastole. These two movements occur in opposition, i.e., when the atria contracts, the ventricles relaxes and so on; all this controlled by the electric impulses generated by the sinus node. The atria receives blood from veins from the lungs and body, and pumps it to the ventricles, that in turn will pump it to the arteries. The entrance and exit of each of the chambers has a valve that prevents the blood from flowing backwards (BLANCO and FEIJÓO, 2011; NICHOLS *et al.*, 2005; PEDLEY and LUO, 1995). Figure 2.2 depicts a transversal section of the heart and its main structures.

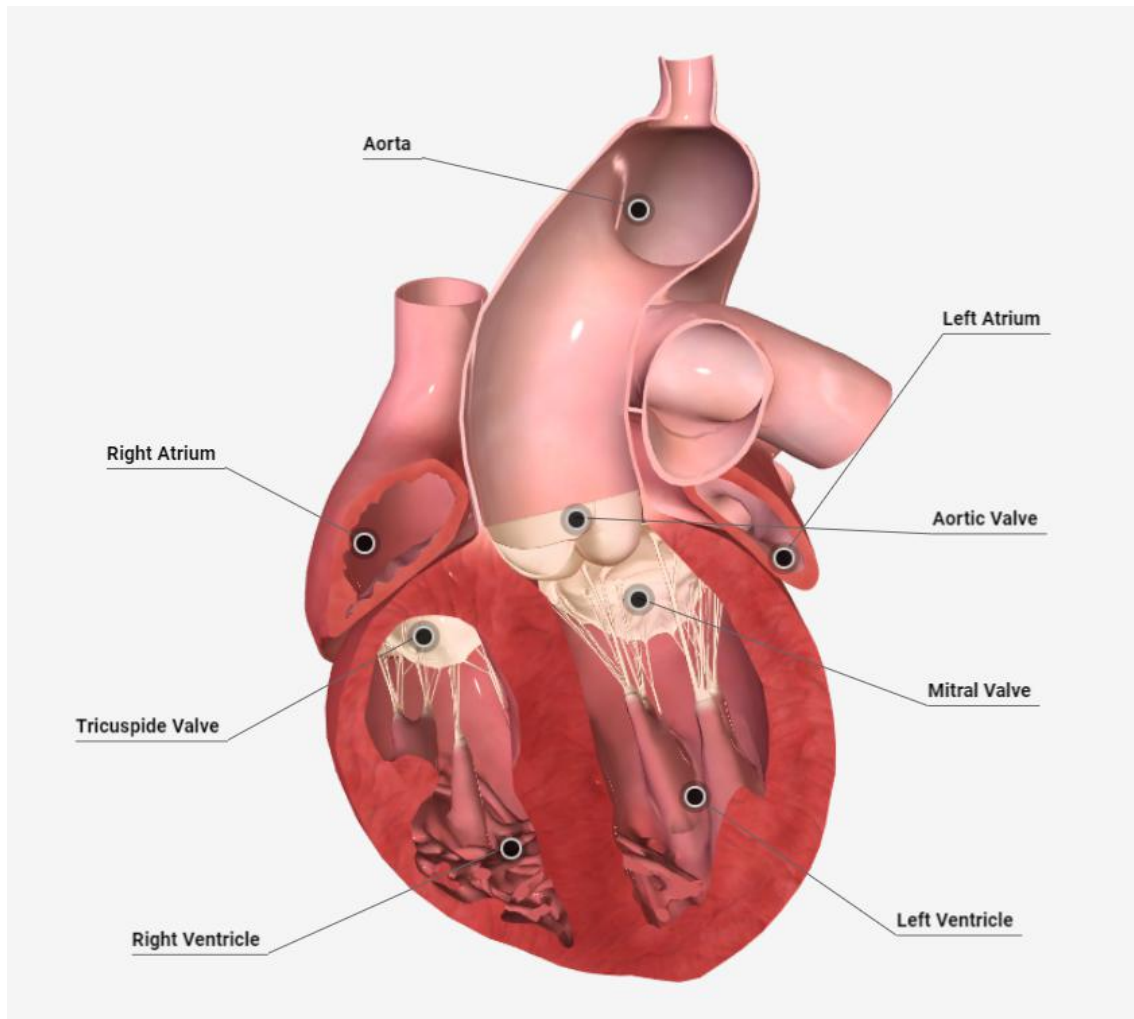
The remaining structures, that completes the system, are the vessels: arteries, veins and capillaries. Large vessels have the structure of its walls divided up into three layers: The tunica intima, media and adventitia. The center of the vessel, where the blood flows, is called lumen. The intima is composed mainly by endothelial cells and collagen fibers and it is the innermost layer and the adventitia contains loosely connective fibers and elastin, and is the outermost



**Figure 2.1:** CardioVascular system and its vessels: arteries (left) and veins (right). Generated with BioDigital3D (BIODIGITAL, 2019).

layer of the vessel. These two have little to no mechanical function, as the cells and fibers are sparsely distributed. On the other hand, the tunica media, that is composed mostly by elastin, collagen and muscle cells, provides the vessels mechanical resistance. These layers change in thickness and in composition with the diameter and the type of vessel. In the arteries, the tunica media is very thick in order to withstand and maintain the pressure in the system, while in the veins this layer is much thinner as the pressure that they undergo is low (BLANCO and FEIJÓO, 2011; NICHOLS *et al.*, 2005; PEDLEY and LUO, 1995). Figure 2.3 illustrates the histology of a vein, with the three tunicas and a representation of a valve that prevent backflow. These valves are positioned at constant spaces throughout the veins. Arteries do not have valves since the pressure is higher and do not need it to maintain the flow.

All the blood that is pumped from the heart goes to arteries that branch out to smaller ones, then to arterioles (minuscule vessels where the three tunicas

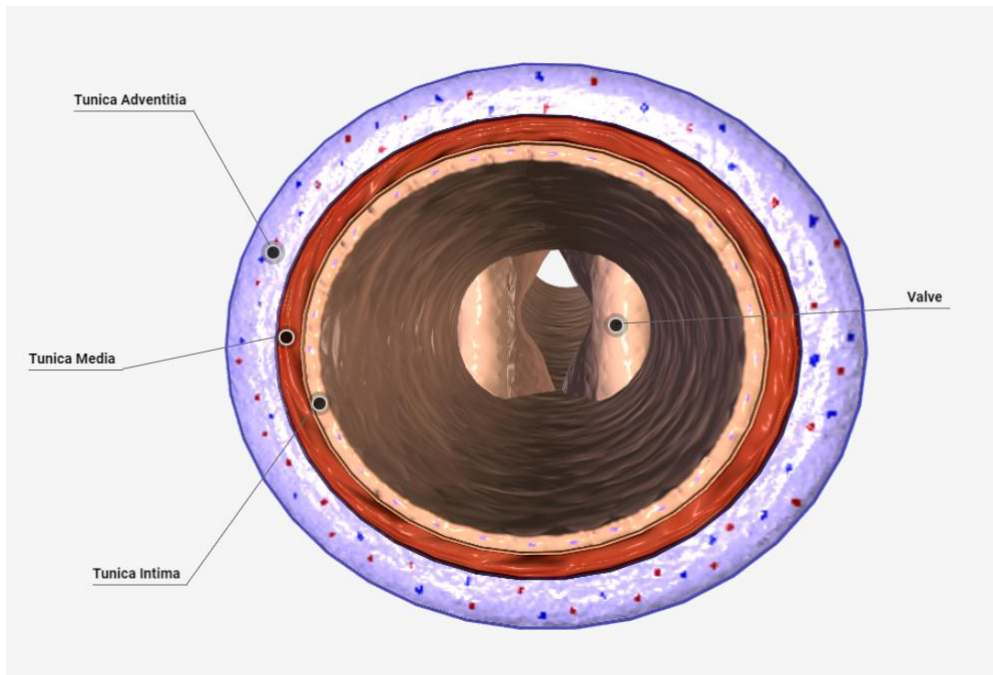


**Figure 2.2:** Heart and its structures. Generated with BioDigital3D (BIODIGITAL, 2019).

are no longer distinguishable); and then to a network of capillaries, where the walls are composed just by endothelial cells that permit the blood perfusion to the tissues. Then the capillaries unite to form the venules, that take the already perfused blood to the veins and finally, back to the heart (BLANCO and FEIJÓO, 2011; NICHOLS *et al.*, 2005; PEDLEY and LUO, 1995).

This process occurs twice at every cardiac cycle. The right side of the heart pumps blood to be oxygenated in the lungs, thus called pulmonary circulation (or small circulation); while the left side of the heart pumps blood to the entire body, thus called systemic circulation (or large circulation) (BLANCO and FEIJÓO, 2011; NICHOLS *et al.*, 2005; PEDLEY and LUO, 1995).

The arterioles caliber can be internally adjusted in order to maintain pressure and flow. That adjustment can be controlled by neuro-regulators or bio-chemical regulators. The neuro-regulation works with the nervous system: when the pressure gets too high or too low, sympathetic or parasympathetic nerves are stim-



**Figure 2.3:** Vein and its structures. Generated with BioDigital3D (BIODIGITAL, 2019).

ulated to regulate the cardiovascular response. Bio-chemical regulation occurs with the presence of a chemical substance that regulates the response, e.g., the sodium can increase the blood pressure (SHI *et al.*, 2011).

Finally, the blood is also a subject of interest. This fluid is constituted of plasma and cells (red cells, platelets, white cells etc.). Its behaviour as a Newtonian or non-Newtonian fluid is important to scientists, who use a more mechanical approach to model the cardiovascular system. In this thesis the physical aspect of the blood will be not dealt with, as a simplified model is employed, although it can be used to be more rigorous with models for the flow inside capillaries, where the diameter of the vessel is roughly equal to the suspended cells in the fluid. Anyway, more complex models can (and will) use rheology data of the blood (BLANCO *et al.*, 2010; VALENCIA and VILLANUEVA, 2006).

## 2.2 Mathematical modelling of the cardiovascular system

Ancient civilizations in the world already used the concept of arterial pulse in order to obtain information to support their diagnosis of diseases. Much has been explained since by mathematical models, but there are still a long way to go in order to fully model this system. In his paper, PARKER (2009) gives more details about the evolution of arterial wave mechanics through the centuries.

FRANK (1899) mathematically formulated the windkessel effect, that was based on old-fashioned fire engines that had a chamber filled with air used to damp the oscillations in the water flow due to intermittent pumping, resulting in a almost perfectly steady flow. His work was the first macroscopic arterial model. It accounted for the resistance and compliance of the vessels, thus being called two-element windkessel model. Although being a good formulation, it did not represent well some aspects of the blood flow and pressure, and was extended to three and four-element in order to overcome this problem (STERGIOPULOS *et al.*, 1999; WESTERHOF *et al.*, 2009).

After Frank's work, electric circuits analogies began to be applied, also used on other fields (FIRESTONE, 1933; HOLANDA, 2015, e.g), to represent the cardiovascular network (WANG *et al.*, 1989). The windkessel and the following models are called macroscopic (or lumped-parameter), as it simplifies the vascular sites as discrete entities that have its spatial characteristics summarized in some parameters. Since the model is not distributed (spatially) it is also called 0D and it will be discussed with more details further on.

Zero-dimensional models give an overall view of the system, but the simplifications make it difficult to combine them with clinical measurements, as it is not easy to obtain those parameters. They are, in general, used to give quantitative insights of the global cardiovascular dynamics, as high dimensional approaches have a intricate structure and thus are limited to local studies (LIANG and LIU, 2005; SHI *et al.*, 2011). Thus, several works couples the zero-dimensional models with high dimensional ones, accounting for the global circulation and more detailed local hemodynamics (BLANCO *et al.*, 2010; CANUTO *et al.*, 2018; KERCKHOFFS *et al.*, 2007; LIANG *et al.*, 2009).

Higher dimensional studies are well documented also (ETHIER, 2002; LIU *et al.*, 2011; MYNARD and SMOLICH, 2015; VALENCIA and VILLANUEVA, 2006; VAN DE VOSSE, 2003; WILLEMET *et al.*, 2015; ?). One-dimensional models uses axisymmetric form of Navier-Stokes equations to provide a pulse wave transmission study (CANUTO *et al.*, 2018; KÖPPL *et al.*, 2018; LIANG *et al.*, 2009); the two-dimensional models accounts for the radial variation in the velocity, however they are not much addressed in literature; in turn, three-dimensional models requires plenty of computational resource, therefore it is generally applied to specific structure with a complex flow pattern, such as the aorta, ventricles, cardiac valves etc., matching a physiological or pathological interest. Those 1-3D models can yield information like shear stress at the wall, that can support a physician's choice for a suture, for example, in order to maintain anastomosis (BULANT, 2017; GUDIÑO and SEQUEIRA, 2017; SHI *et al.*, 2011). Zero-dimensional models lead to a set of ordinary differential-algebraic equations,

whilst the higher dimensional models constitute a set of partial differential equations, that has a higher computational cost. These equations describe the conservation of mass and momentum as well as the constitutive relations.

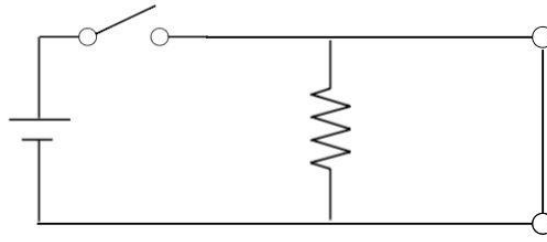
The mass transfer problem is less well addressed in the literature comparing to the models for the general system and its diseases (stenoses, aneurysms etc.). In fact, there are a very few studies that assess this problem with a global view, i.e., the majority of the reported studies assess the mass transportation from the lumen of the vessels *through* its wall and in a specific location, as it is used most in higher dimensional models (KAAZEMPUR-MOFRAD and ETHIER, 2001; RAPPITSCH and PERKTOLD, 1996; VALENCIA and VILLANUEVA, 2006; ?). In other words, there are few to none mathematical studies of how a compound (excluding the components of blood) is transported through the vascular system around the body. This matter will be better assessed later.

### 2.2.1 The 0D Resistive-Compliant model

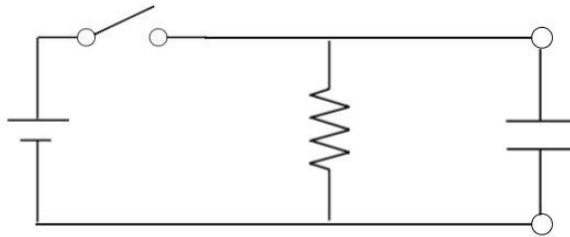
Before get to the full explanation of the OD model, some ideas must be discussed in advance. To make analogy with an electric system is not exclusive of cardiovascular models. That analogy is vastly used in many fields (FIRESTONE, 1933; HOLANDA, 2015) in order to simplify the system. This approach is usually called capacitance-resistance model (CRM).

In order to understand the parameters RLC (resistance, inertance and capacitance) of this model, it will be analyzed the circuit in Figure (2.4) that has a font, a resistance and a switch. When the switch is open, no current passes through the resistance, whereas when it is closed, there is a current in the system. Now, if this switch opens and closes the circuit regularly, that current would be on and off with time. But if a capacitor is added, like in Figure (2.5), when the switch is closed the capacitor charges and when the switch is open, the capacitor discharges maintaining the resistor under a current. Now, if once again the switch goes on and off regularly, the presence of the capacitor will ensure a non-null current until the next cycle (AMBROSI *et al.*, 2012; BLANCO and FEIJÓO, 2011).

In the cardiovascular model, when the switch is on, is the equivalent to systole; and when its off, diastole. The electrical resistance is analogue to the vessel resistance that opposes to the flow. Finally, as the vessels are elastic, when the high pressure flow comes in, it dilates and stores potential elastic energy, releasing it back to the fluid as the pressure diminishes in order to maintain the fluid circulating. That is called compliant model, thus the name of this model based on this analogy: Resistive-Compliant model (AMBROSI *et al.*, 2012; BLANCO and FEIJÓO, 2011).



**Figure 2.4:** Resistive circuit with switch.



**Figure 2.5:** Capacitive-resistive circuit with switch.

Table (2.1) summarizes the analogies between these two systems.

**Table 2.1:** CRM's underlying analogies.

	Capacitor Resistor circuit	Cardiovascular system
<b>Driving force</b>	voltage difference, $\Delta E$	pressure difference - $\Delta P$
<b>Flow equation</b>	Ohm's law, $I = \frac{\Delta E}{R}$	$Q = \frac{\Delta P}{R}$
<b>Resistance, R</b>	$f_1$ (material property, Ac, L)	$f_2$ (tissue property, Ac, L)
<b>Capacitance, C</b>	$C = \frac{q}{\Delta E}$	$C = \frac{\Delta V}{\Delta P}$

The study from WESTERHOF *et al.* (1969) is among the firsts to present the electric-circuit analogy applied to the cardiovascular system, and to use the CRM to a arterial tree. They considered Newton's law and continuity equations to model the flow in any length of the artery, as shown in Equations (2.1) and (2.2), respectively.

$$-\Delta P = L \frac{dQ}{dt} + RQ \quad (2.1)$$

$$\frac{dV}{dt} = C \frac{dP}{dt} \quad (2.2)$$

where

$$\text{resistance, } R = \frac{8\pi\eta l}{A^2}$$



$$\text{compliance, } C = \frac{A}{E(h/2R)}$$

$$\text{inertance, } L = \frac{\rho}{A}$$

and:

$\nu$  is the blood viscosity;

$\rho$  is the blood density;

$E$  is the Young's modulus of the blood vessel;

$A$  is a cross-sectional area of the segment of artery;

$h$  is the wall thickness of the vessel.

WANG *et al.* (1989) also applied this analogy to their model to simulate disease conditions (the effect of stenosis in a few cases), using a coefficient  $\alpha$  to correct the three initial parameters ( $R$ ,  $C$  and  $L$ ) in order to represent a stenosed artery. The study results are representative, even in disease cases. It is important to point out that their study only approached the coronary arteries, and the RCL parameters were dependent of the length of the segment of artery (after integration) that difficult its estimation. Although further developments were made, the capacitance-resistance model is since the most used macroscopic model in the field of cardiovascular systems (BLANCO and FEIJÓO, 2011; BLANCO *et al.*, 2010; DUANMU *et al.*, 2018; LIANG and LIU, 2005; LIANG *et al.*, 2009; SHI *et al.*, 2011; STERGIOPULOS *et al.*, 1999).

## 2.2.2 The 0D compartmental models

As previously said, the two-element windkessel (FRANK, 1899) was the first macroscopic model that consisted of a peripheral resistance of the vessel and its capacitance, this last one being determined mainly by the elasticity of the large arteries, Equation (2.3) (PARKER, 2009; WESTERHOF *et al.*, 2009)). Even though it is very simplified, Frank's model is still used until these days in clinical practice for the estimation of the total arterial compliance.

$$P_{dia}(t) = P_{es}e^{-\frac{t}{RC}} \quad (2.3)$$

where  $P_{es}$  is the end-systolic aortic pressure (start of diastole) and  $P_{dia}$  is the diastolic aortic pressure.

On the other hand, this model has several drawbacks as it does not account for veins pressure (assumed as zero) and does not represent the impedance of the proximal aorta in high frequencies since it has only one time constant. By the time that the model was formulated, it was possible to measure only the aortic

pressure, but with the advent of modern equipments and measurements it was noticed that Frank's model failed to predict aortic systole (BURKHOF *et al.*, 1988; LIANG and LIU, 2005; PARKER, 2009; SHI *et al.*, 2011; STERGIOPULOS *et al.*, 1999; VAN DE VOSSE and STERGIOPULOS, 2011; WESTERHOF *et al.*, 2009).

Following studies enhanced the model by adding a third element to account for the impedance of the arterial network, improving the prediction at high frequencies. This model became known as RCR (as the windkessel is the RC). Although being widely accepted macroscopic model, the three-element windkessel still has significant limitations since the oscillations in the aortic impedance are not modeled and the estimations for the capacitance and impedance are severely compromised (LIANG and LIU, 2005; PARKER, 2009; SHI *et al.*, 2011; STERGIOPULOS *et al.*, 1999; WESTERHOF *et al.*, 2009). To overcome this problem, it was proposed a fourth element to the model, a inertia term or inertance (RLCR). STERGIOPULOS *et al.* (1999) compared the predictions of the RCR and RLCR windkessel models, showing that the latter returns a better fit of experimental data. Moreover, the authors gave a physiological meaning for the fourth term as the summation of all the local inertances of the arterial system. The problem seems to be difficulty to estimate the inertance. Further developments on this matter only rearrange the equations or include more parameters, originating even more difficult to apply models that are not widely used and thus will not be further discussion to assess this issue.

The windkessel model and later developments aforementioned, can be classified as mono-compartment models, since the whole vasculature is treated as a single block with resistance (R), compliance (C) and inertance (L), hence, this type of models does not account for the internal pressure and flow-rate distribution. These drawbacks can be tackled with multi-compartments models that represent the vessel network as separated blocks (or compartments) for each chosen site of this network that are described by its own RCL parameters depending on block's position. The system compartmentalization can be assessed by the particular needs of each study, but each block must have its own derivation of RCL models according to its local, e.g., a vessel cannot be modeled the same way as a cardiac valve (LIANG and LIU, 2005; SHI *et al.*, 2011).

While the mono-compartment models can represent the whole body, this is also possible for multi-compartmental models using closed-loop systems. An interesting idea is that a multi-compartmental model taken to the limit of its segmentation should be similar to a 1D model. For SHI *et al.* (2011) the convective acceleration term in 1D models is the main difference between the former and 0D models. This study uses a multi-compartmental closed-loop macroscopic

model and all the vessel network segmentation and required equations will be approached in Chapter 3.

Finally, a major drawback regarding macroscopic models is the difficulty to obtain the values for the parameters. Many studies rely on experimental data for its parameters, but they are often incomplete, have limited precision and, most important, are invasive. If the whole argument of having a numerical model to support physicians diagnosis is to diminish invasive procedures than these models fall short. Thinking about that, in a recent study, MEI *et al.* (2018) presented a model for the windkessel effect with a mechanist theory based on the fluid-structure interactions, where "the empirical parameters can be theoretically derived in terms of the structural properties of the vessel system".

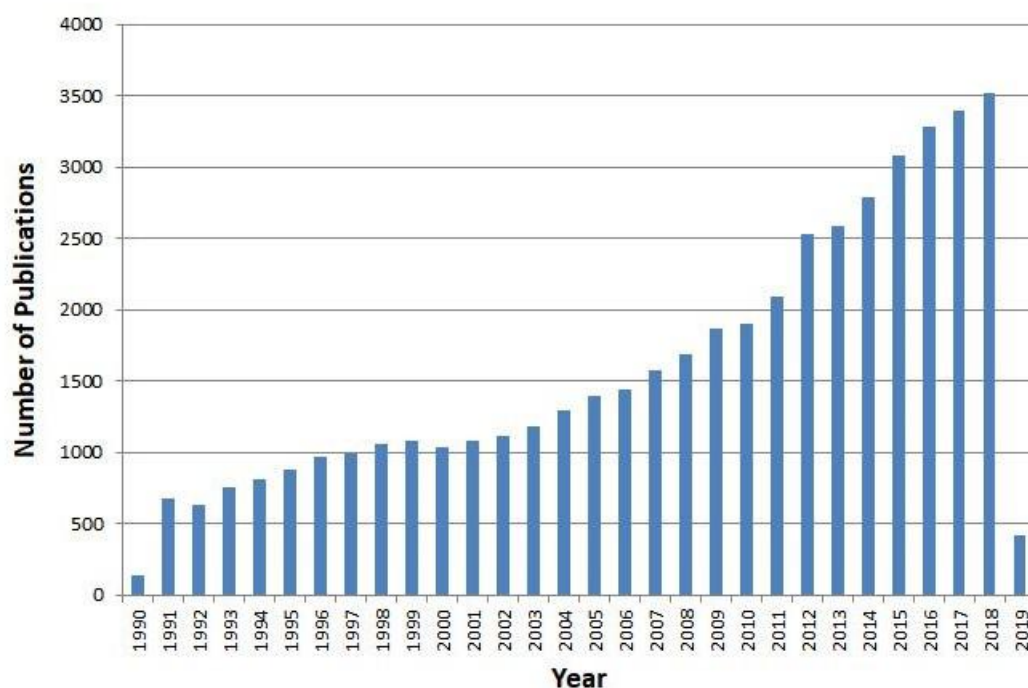
## 2.3 Pharmacokinetics

During drug development process, or during therapy, it is important to know how that chemical will be dealt with throughout the body. "What is the target tissue for the drug?", "What concentration that is needed in said tissue, and how much have to be administered to achieve that concentration?", "How it will be administered?", "Which chemical processes the drug have to endure until it can reach the target tissue?" are, among others, questions that have to be answered if anyone wants to successfully develop/prescribe a drug.

Most of those questions will be answered by studying the pharmacokinetics of the drug. Using the concepts of chemical kinetics and physiological parameters, allied to experimental data, it is possible to study the behavior of drugs introduced in a living body, providing physicians and health professional actual scientific basis rather than relying on rules of thumb to prescribe a drug treatment.

Pharmacokinetics is widely approached in the literature as well as its models. However, the coupling of drug kinetics with fluid mechanics could not be found in literature. To illustrate, a analysis of publications in the Web of Science database was made for the cross between the key words "pharmacokinetics" and "models" and "PBPK". Figure 2.6 shows plot results of publications per year for the last 25 years. Although that seems much, when crossing "pharmacokinetics" with "drug delivery", "0D model", "mass transport" or "fluid mechanics", until the writing of this study, it was not found any study that approached the circulation-drug system from a mechanical point-of-view, accounting for both fluid mechanics and pharmacokinetics, as is presented here.

Usually, models for drug delivery throughout the body are empirically based, i.e., there is no mechanical models included and they rely mostly on the con-



**Figure 2.6:** Number of publications per year just for studies with the key words “pharmacokinetics”, “model” and “PBPK”. Obtained from Web of Science database.

centrations of the drugs obtained by experimentation and on chemical kinetics. Even though those models are useful, understanding the fluid mechanics could improve predictions, moreover, another applications could arise from the coupling. A example could be to monitor the formation and displacement of thrombus in the body.

### 2.3.1 Initial Concepts

In order to proceed, it is important to introduce some important concepts (DE-DON *et al.*, 2013; DI and KERNS, 2015).

- **Xenobiotic:** Chemical substance found within an organism that is not naturally produced or expected to be present within the organism;
- **Plasma:** Liquid portion of blood where all particles are suspended, accounts for 55% of all human blood volume;
- **Absorption:** In pharmacokinetics, the absorption of a xenobiotic occurs when it crosses the a plasma membrane and enters the bloodstream from an external source. The rate of absorption will be limited either by the kinetic of its transport through the membrane or by blood flow, when the

kinetic is fast enough. A number of variables can affect this rate, like pH, blood pressure, solubility, degree of ionization of the component, residence time, among others. When the xenobiotic reaches the bloodstream without having to cross a plasma membrane, like in an intravenous injection for example, it is said that there is no absorption.

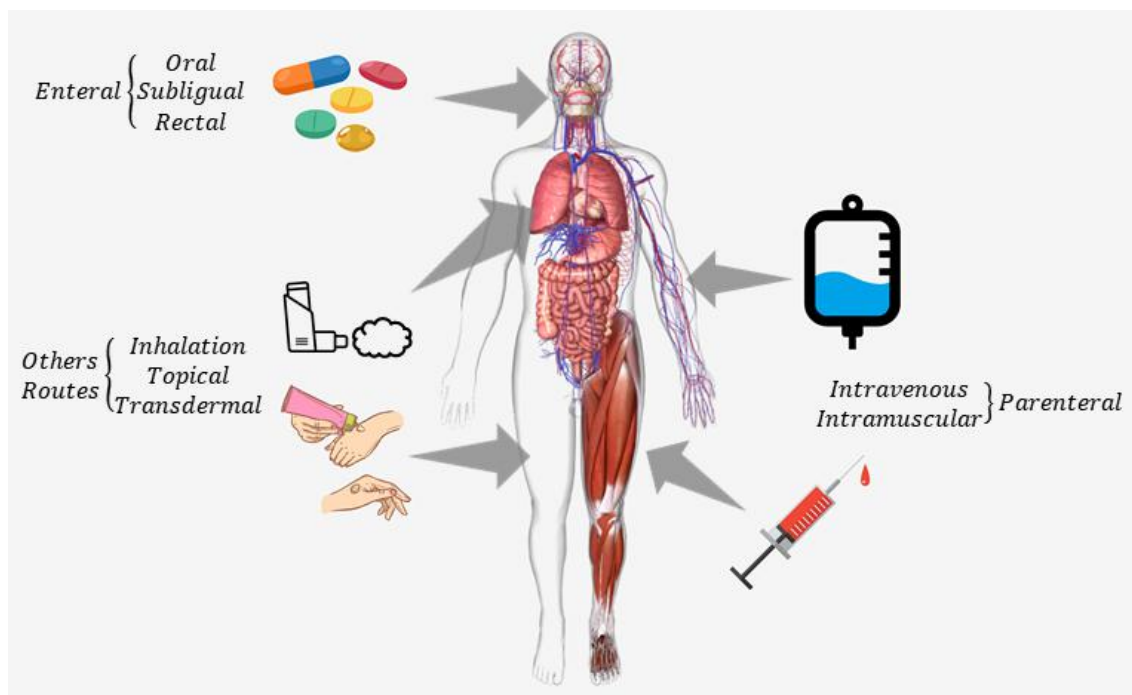
- **Distribution:** the distribution occurs when a xenobiotic leaves the bloodstream and enters the tissue.
- **Volume of Distribution ( $V_d$ ):** Is the ratio between the amount of chemical in the body and its plasma concentration. It indicates how widely a compound is distributed in the body. Usually is expressed in terms L/kg of body weight or mL/kg of body weight;

$$V_d = \frac{\text{Amount of drug in body}}{\text{Concentration in plasma}}$$

- **Plasma Clearance (Cl):** Volume of plasma completely cleared of drug per unit time by all routes and mechanisms. Usually is expressed in terms of  $\frac{\text{mL}}{\text{min/kg}}$ .
- **Bioavailability (F):** Percentage of a drug dosage that actually reaches the bloodstream. For intravenous administrations, bioavailability is 1;
- **Plasma half-life of a drug ( $t_{1/2}$ ):** Time for the concentrations of a chemical in plasma to reduce in half;
- **Partition coefficient:** Measures the affinity of a given chemical for a tissue, relative to blood:

$$\beta = \frac{\text{Concentration of the chemical at the tissue}}{\text{Concentration in plasma}}$$

Once in the bloodstream a chemical will be distributed to the tissues where it can be stored, metabolized or eliminated. Likewise the absorption, distribution can be perfusion driven or diffusion driven, depending on the limiting factor for the transport through the cell barrier. However, even though this is true for equilibrium, in early stages of distribution, highly perfused organs may achieve higher concentrations of a chemical than low perfused ones, regardless of partition coefficients. Nonetheless, by final stages of distribution the chemicals are redistributed and the relative affinity of the component for a specific tissue will determine which tissue will receive more chemical (DIX, 2001).



**Figure 2.7:** Illustration examples of drug administrations via enteral, parenteral and other routes. Generated via BioDigital3D (BIODIGITAL, 2019) and adapted.

Some chemicals can be stored in the body and be redistributed later, due to an equilibrium displacement process. When the concentration of the chemical lowers in the body, then the equilibrium is displaced and some of the stored chemical will be liberated in the system. The fat is an excellent storage depot for lipophilic chemicals, including toxins and when the body consumes the fat, these chemicals will be again released in bloodstream (that is why losing weight very fast can cause many problems), while bone tissue is a good storage depot for metals (DIX, 2001).

The routes of drug administration are presented in Figure 2.7. As mentioned before, the absorption phase is bypassed when intravenous (IV) injections are performed. Aside from being delivery straight to the bloodstream, a drug has to undergo absorption. It is important to understand each mechanism of absorption in order to understand how the chemical will reach the bloodstream and which is the concentration at that point. The mass transfer in the absorption phase greatly decreases the concentration of a chemical when compared to an IV administration. In absorption, one must consider mainly the metabolism and the partition coefficients for the tissues involved (DEDON *et al.*, 2013).

When something enters the body orally it gets into the gastrointestinal tract. This tube is covered with mucosa tissue, that is highly irrigated. The intestines have a large surface area that aids in the absorption of chemical that still could not pass the plasma barrier in the stomach. All the chemicals absorbed in the

gastrointestinal tract enters the portal circulation, through the portal vein, and gets metabolized by the liver (with exception from via sublingual and anal, that goes straight to the bloodstream). That has to be taken into account when modeling drug distribution, because most of the drugs are metabolized and inactivated by the liver, when taken orally, reducing the actual concentration of the chemical that is to be delivered throughout the body, rendering an incorrect model for component distribution (DIX, 2001).

The gas-exchanging region of the lungs also are rich in capillaries, that allows chemicals permeate to bloodstream. For any chemical to be absorbed by the lungs it has to be in a gas, vapor or particulate (suspended in air) form. On the other hand, dermal doses are the ones with lowest absorption rates among these, since the outmost part of the skin is not so perfused as the other tissues, what makes it a good barrier for the body. Most part of drugs designed for the skin (e.g. lotions) do not even reach the blood stream and, therefore, have just local action, generally being just washed off (GARFITT *et al.*, 2002).

### 2.3.2 Pharmacokinetics models

The absorption and distribution of any chemical is carried out at the level of the capillaries. The thin membrane of these structures allows the exchange of molecules from bloodstream to tissue and vice versa. It means that the larger the surface area of a tissue, the better the absorption/distribution occurs in it. Also, the pores size of cells can improve or decrease the amount of chemicals that crosses its membrane. In the kidney, for example, the pores are considerably larger than the ones on other cells of the body. That increases the quantity of molecules that can be transferred from blood to the kidney, therefore aiding the removal of toxins from the system (DIX, 2001).

The reiterated exposure to a xenobiotic chemical has to be taken into consideration in a specific model, as it influences its storage in the body, and therefore, its concentration. If the time between exposures is longer than the half-life of the chemical in the body, then its unlikely to be stored in the body. However, if the time between exposures is smaller than the half-life, then the chemical will be stored (DIX, 2001).

There are several models widely used in the field of pharmacokinetics that are separated in two great groups: Non-compartmental and Compartmental models. The latter can be divided into classical and physiologically based models (PBPK). The main goal of these models is to predict the blood concentration of a drug and its variation in a period of time. The Non-Compartmental models, as the name suggests, do not compartmentalize the body into segments to

be modeled separately, but relies on the statistical moment theory in order to analyze plasma-concentration vs. time data (DIX, 2001). Non-Compartmental models are not the subject in this research and will not be further addressed.

As discussed in Section 2.2.2, compartmental models are characterized by the division of the system into one or more compartments, each one with its set of equation that describe its intrinsic dynamics as well as the interaction (mass/energy transfers) between them. Also, in each compartment all the stream components (chemicals, fluid, components, parameters etc.) are equally distributed, i.e., all compartments are homogeneous. Figure 2.8 show examples of one and multi-compartmental models.

According to DIX (2001), classical compartmental models can be used in pharmacokinetics to obtain volume of distribution ( $V_d$ ), absorption and eliminations rates constants, elimination half-life and plasma clearance (Cl), that are essential parameters to represent a chemical transport throughout the body.

One-compartment model is adequately used to describe the pharmacokinetics of rapidly equilibrating chemicals (between blood and tissue), and models the body as a single homogeneous compartment. But when the kinetic is not fast, or during excretion (elimination) of the chemical, this model cannot provide an accurate concentration profile. Therefore multi-compartment models are required. Usually, for a multi-compartment approach, one-compartment model is used for the rapidly equilibrating tissues, such as the ones which have higher perfusion, when the others are modeled separately. In both approaches, the elimination is assumed to occur only from a single compartment. In multi-compartment models the absorption, distribution and elimination are modeled as only linear or first order processes (DIX, 2001).

Although useful, classical compartmental models do not represent physiological or anatomical reality. On the other hand, PBPK models are designed to represent that reality. Since the modeling for this research is based on PBPK models, further details of the method will be dealt with.

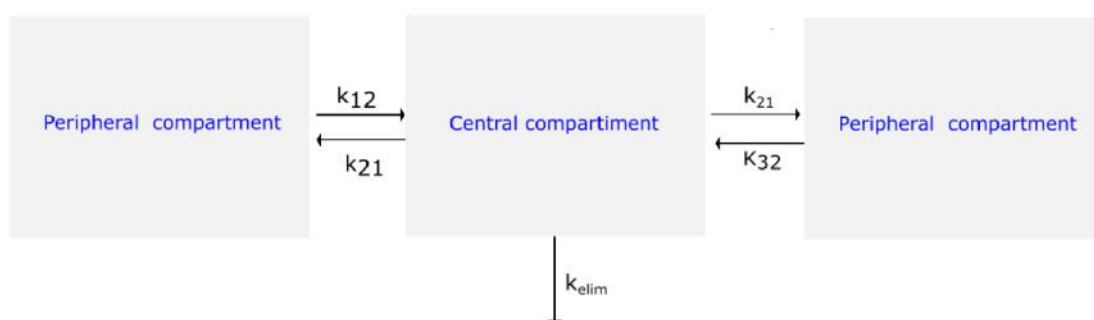
### **Physiologically Based Pharmacokinetics models**

Physiologically Based Pharmacokinetics models (PBPK) provide an approach minding the physiological and anatomical aspects of the system. For this kind of model, the compartments represent organs or tissues and are connected by bloodstream. A xenobiotic may enter the body by any route (oral, dermal, inhalation and intravenous) as well as it can be eliminated by urinary excretion (kidneys), exhalation (lungs) and metabolism (liver). In order to develop a PBPK model, one have to consider the type of chemical that is being dealt with in order





(a) One-compartmental model



(b) Multicompartmental model

**Figure 2.8:** Pharmacokinetics models: one and multi-compartmental.

to add/remove some site of greater/smaller importance, i.e., a target tissue for a specific drug can be added, for example, in order to monitor the concentration of the drug in that specific place. It may be important to add skin, gastrointestinal tract and lungs, for example, due to the fact that these sites are a great absorption site for chemicals when dealing with oral, dermal and inhalation doses, for example. Figure 2.9 show an example of a PBPK compartmentalization. Regarding distribution, it is useful to include highly perfused tissues and poorly perfused tissues so to provide a better prediction of plasma concentrations in early and final stages of this process. Fat is usually also included in PBPK model due to the high partition coefficient of lipophilic chemicals.

Once the modeling sites are defined, a PBPK model require a mass balance for each compartment and its parameters are specific for each drug and site tissue. According to BROWN *et al.* (1997), a key point to PBPK model accurate predictions is the parameter characterization, considering that the major advantage of such models is the possibility to represent more specific systems with the same model structure just by choosing the right set of parameters for each individual case.

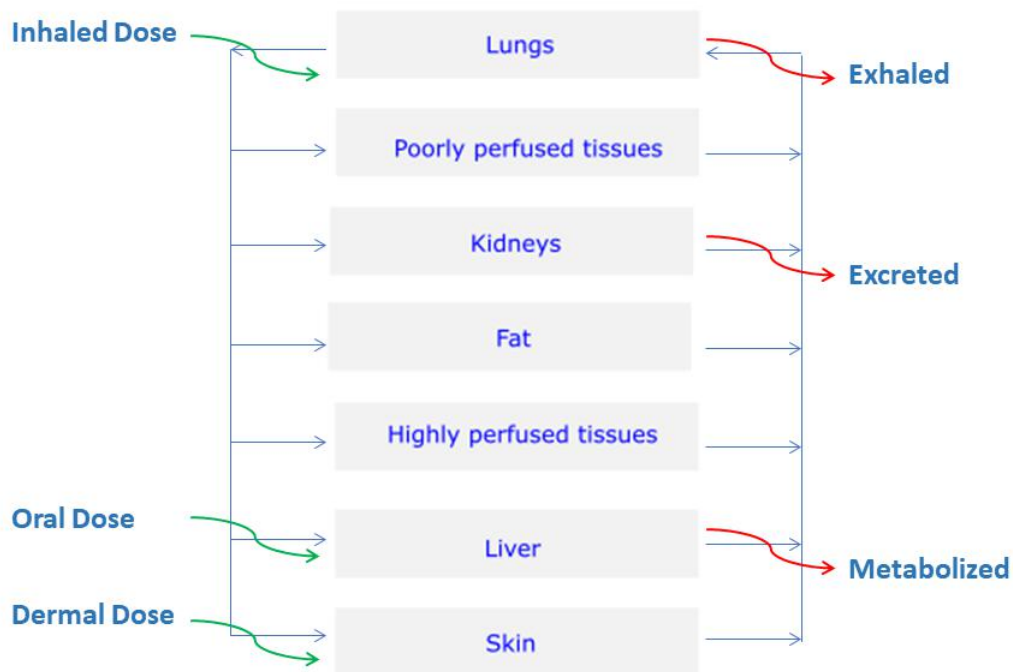
DIX (2001) divides PBPK's parameters into three groups: physiological, physicochemical and biochemical. Physiological parameters comprises the characteristics of the biological system itself, e.g., cardiac output, tissue volumes, blood flow etc. The physicochemical parameter or tissue partition coefficient describes the relative solubility of the chemical in the media whilst biochemical parameters are the ones that depict the interaction between chemical and tissue, like the absorption, distribution and elimination rates as well as the macromolecular binding. The latter is the trapping of a chemical by a protein in the body and can significantly change the concentration of a drug in the bloodstream when the binding is suddenly broken (like the rapid loss of weight, as mentioned before). Physiological parameters depend only on the underlying aspects of the body and will be constant for several cases whereas physicochemical and biochemical parameters are dependent on the compound properties and thus are case-specific. Even though this is true, some physiological parameters may vary in some cases, but these changes can be accounted for in the model if necessary. Anyhow, these parameters tend to be constant. The administration route is an important input in any PBPK modeling. Each route will lead a chemical through different tissues with distinct properties and thus distinct physiological parameters. For example, a oral intake will force the drug to undergo what is called first-pass effect, that consists in taking the drug through the portal system to be metabolized in the liver, which may significantly reduce its bioavailability. (DEDON *et al.*, 2013)

## 2.4 EMSO Simulator

Environment for Modelling, Simulation and Optimisation (EMSO) was presented by SOARES and SECCHI (2003) as a tool for dynamic processes simulation. EMSO is a object-oriented language, open-source software that allows the user to inspect and edit built-in models as well as create new ones, what makes it widely applicable. Another compelling characteristic of EMSO is the auto-check consistency of units, initial conditions and system solvability. EMSO employs index reduction methods for solving high-index differential-algebraic equations (DAE). The coding is very straightforward and all equations can be written as it is, without the need to isolate variables or translate as a state-space form, what is time-saving.

SOARES and SECCHI (2003) presents three major entities in EMSO language:

- **Models:** Mathematical abstraction of a *device*
- **Device:** A particular application of a *model*. A single model can have several



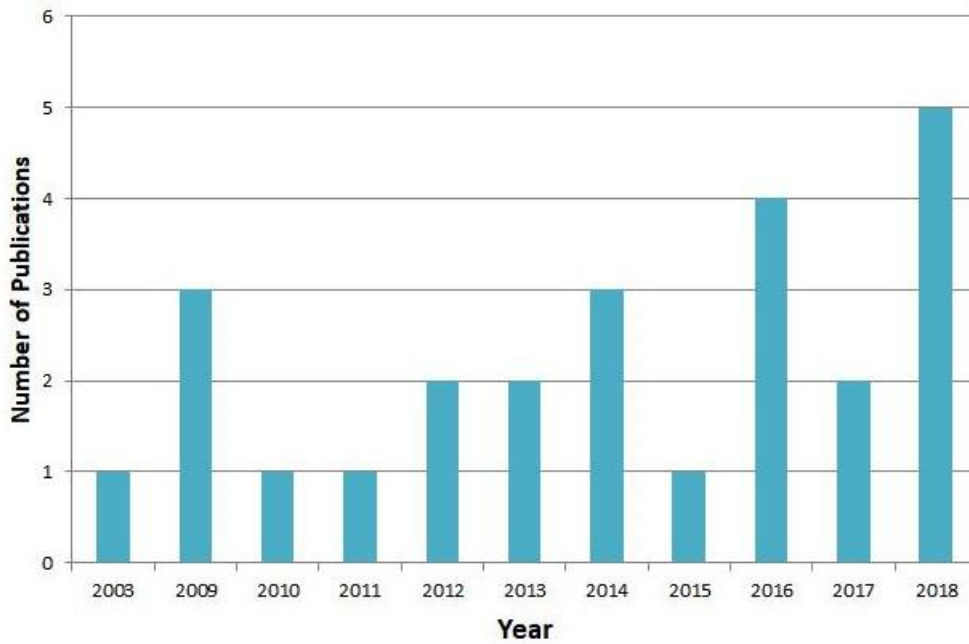
**Figure 2.9:** Physiologic Based Pharmacokinetics model (PBPK).

devices distinguished by its parameters, specifications and so forth.

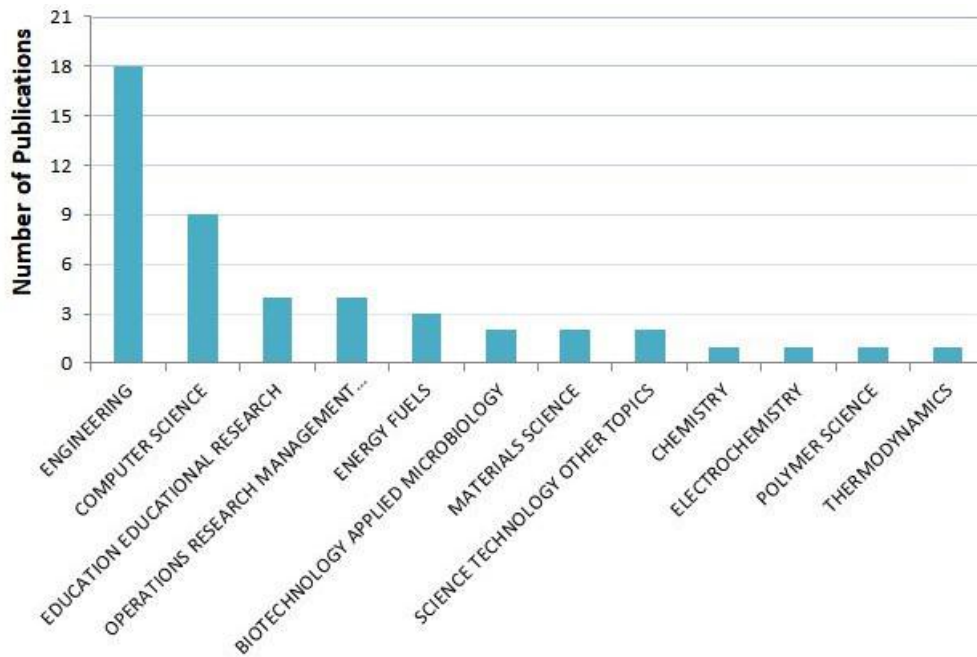
- **Flowsheet:** Represents the process to be analyzed, that is a connection of *devices*

EMSO has been gaining recognition over the years and several studies were presented using the software. However, none of the studies simulated complex living systems. Figure 2.10 depicts published studies involving EMSO since its presentation by SOARES and SECCHI (2003) while Figure 2.11 depicts the fields of study that EMSO is applied in published papers.

EMSO was chosen for the simulations for the possibility of defining the models separately and then put everything together at flowsheet environment, creating “devices” that are declared as a type of each model previously defined. Those devices are then connected simply by linking the output of one compartment to the input of another in just one line of code. The model is defined with all its parameters, variables and equations. In this study, six types of models were created (those models are presented in the Chapter 3). All these models become a type for the devices that are later declared in the flowsheet. Once the devices are set as each model, they can be connected to each other. In other words, once the models are implemented, all the sites that can be modeled by that specific model need just to be assigned to that model, i.e, one does not need to implement a

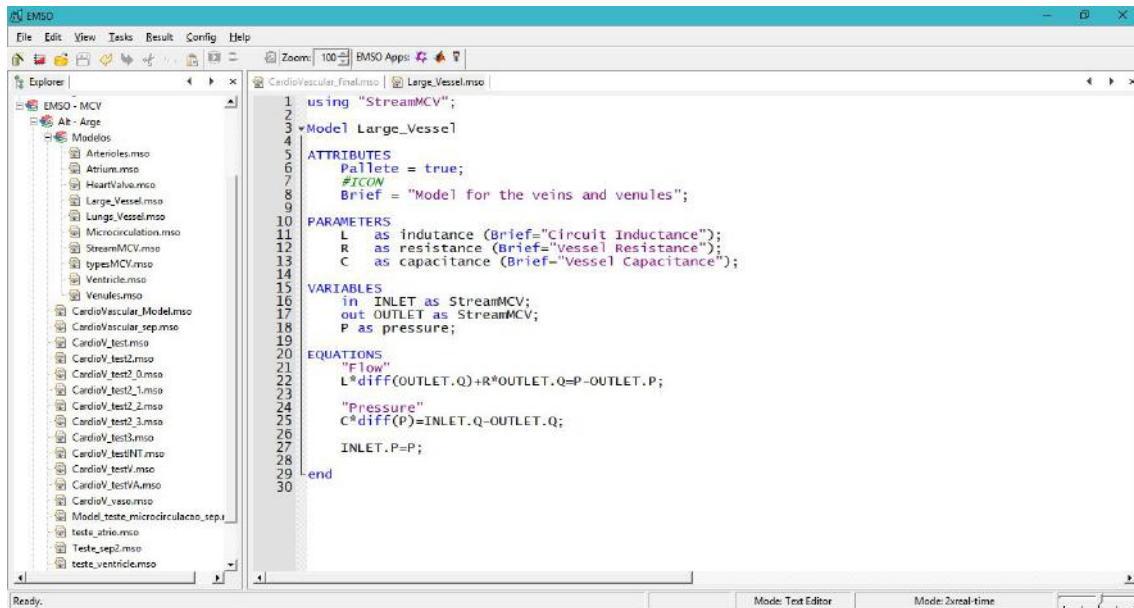


**Figure 2.10:** Studies involving the EMSO simulator since 2003. Obtained from Web of Science database.



**Figure 2.11:** EMSO applications in simulations on different fields. Obtained from Web of Science database.

unique model to each and every one of the sites to be simulated. EMSO also provides a graphic interface, as an option to the written flowsheet, where one can define devices and make connections by dragging icons from the palette into the workspace and graphically connect one to another as well as set the parameters and so on. That way is easy to add or remove sites/compartments without



**Figure 2.12:** Example of model implementation in EMSO.

having to change large portions of code. That graphic environment resembles the Symulink by MathWorks®, but with the convenience of a open-source software. Figures 2.12 to 2.14 illustrates examples of implementation, in EMSO, of models, devices and connections.

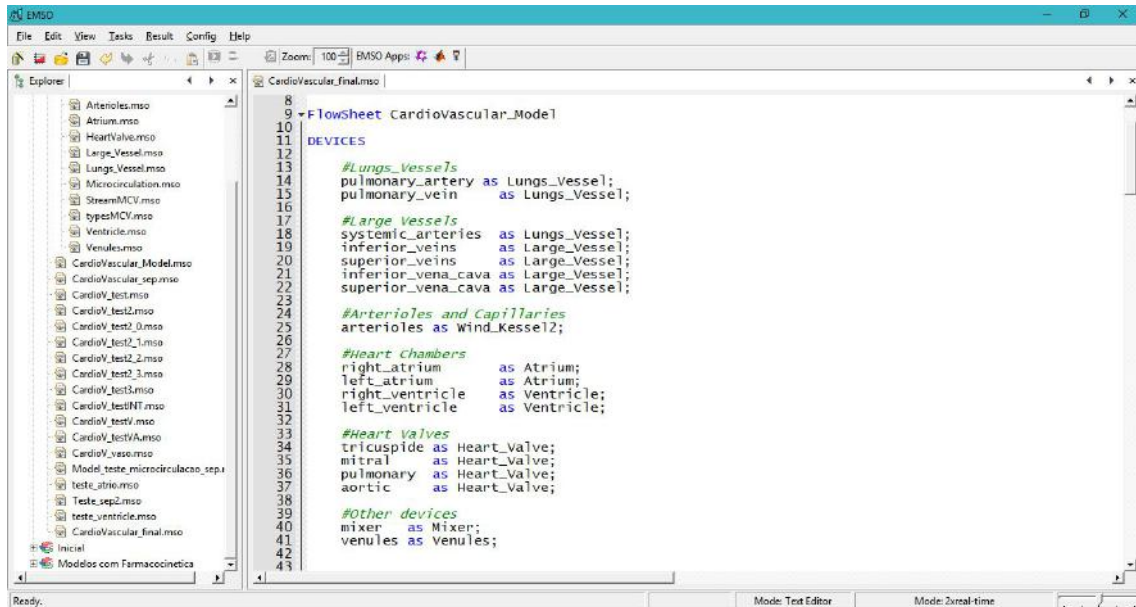


Figure 2.13: Example of "Device" declaring in EMSO flowsheet.

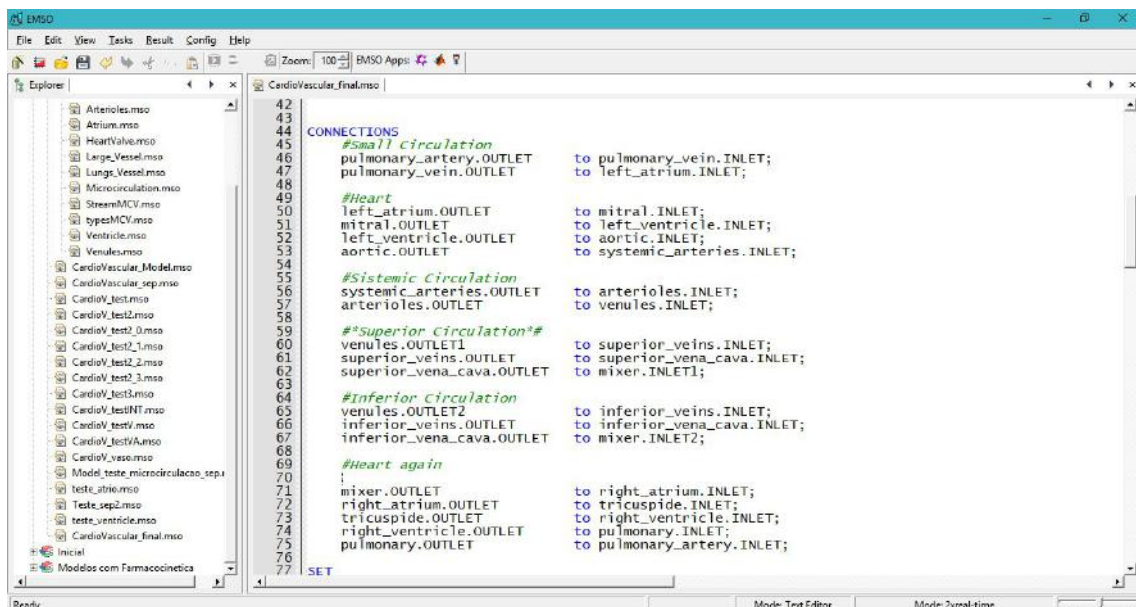


Figure 2.14: Example of "Connections" declaring in EMSO flowsheet.

# Chapter 3

## Methodology

### 3.1 The closed-loop macroscopic model in a cardiovascular system framework

As mentioned before, in this study approach is applied to a multi-compartmental model for the circulation. This method permits a better assessment of the problem and improves the system response (prediction) when compared to the open-loop mono-compartmental model, as well as consists on a simplified option to the 1D spatial discretization with less computational cost. Furthermore, it is important to point out that the cardiovascular system has a transient behavior.

In order to use the multi-compartmental approach, first it was necessary to divide the sites of the system network into four categories: heart chambers, heart valves, large vessels and microcirculation, regarding their specific model. Once this first distinction is assessed, any spatial compartmentalization can be chosen, considering that the difficulty to obtain parameters increase significantly with the spatial discretization. For this study the cardiovascular system was divided into 18 compartments that are specified in Table 3.1. Figure 3.1 illustrates the physiology of the body while, Figure 3.2 illustrates a process flowchart for the cardiovascular system with the compartments presented in Table 3.1. The tissue compartment for this primary part is only a pass-through object. The pharmacokinetics will be addressed later.

In the next sections the macroscopic models used for each of the compartment will be described. The approach used here for the cardiovascular model has been widely applied (ABDOLRAZAGHI *et al.*, 2010; BLANCO and FEIJÓO, 2011; BLANCO *et al.*, 2010; DUANMU *et al.*, 2018; LIANG and LIU, 2005; LIANG *et al.*, 2009; WANG *et al.*, 1989, e.g.).

**Table 3.1:** Compartmentalization of the system network.

Category	Compartment
<b>Heart Chambers</b>	Right atrium (RA)
	Left atrium (LA)
	Right ventricle (RV)
	Left ventricle (LV)
<b>Heart Valves</b>	Pulmonary (Pu)
	Mitral (Mi)
	Tricuspid (Tr)
<b>Large Vessels</b>	Aortic (Ao)
	Pulmonary artery (PA)
	Pulmonary veins (PV)
	Systemic arteries (SA)
	Inferior venules (IVen)
	Inferior veins(IV)
	Inferior vena cava(IVc)
	Superior venules (SVen)
Superior veins (SV)	
<b>Microcirculation</b>	Superior vena cava (SVc)
	Arterioles and capillaries (AC)

### 3.1.1 Heart chambers

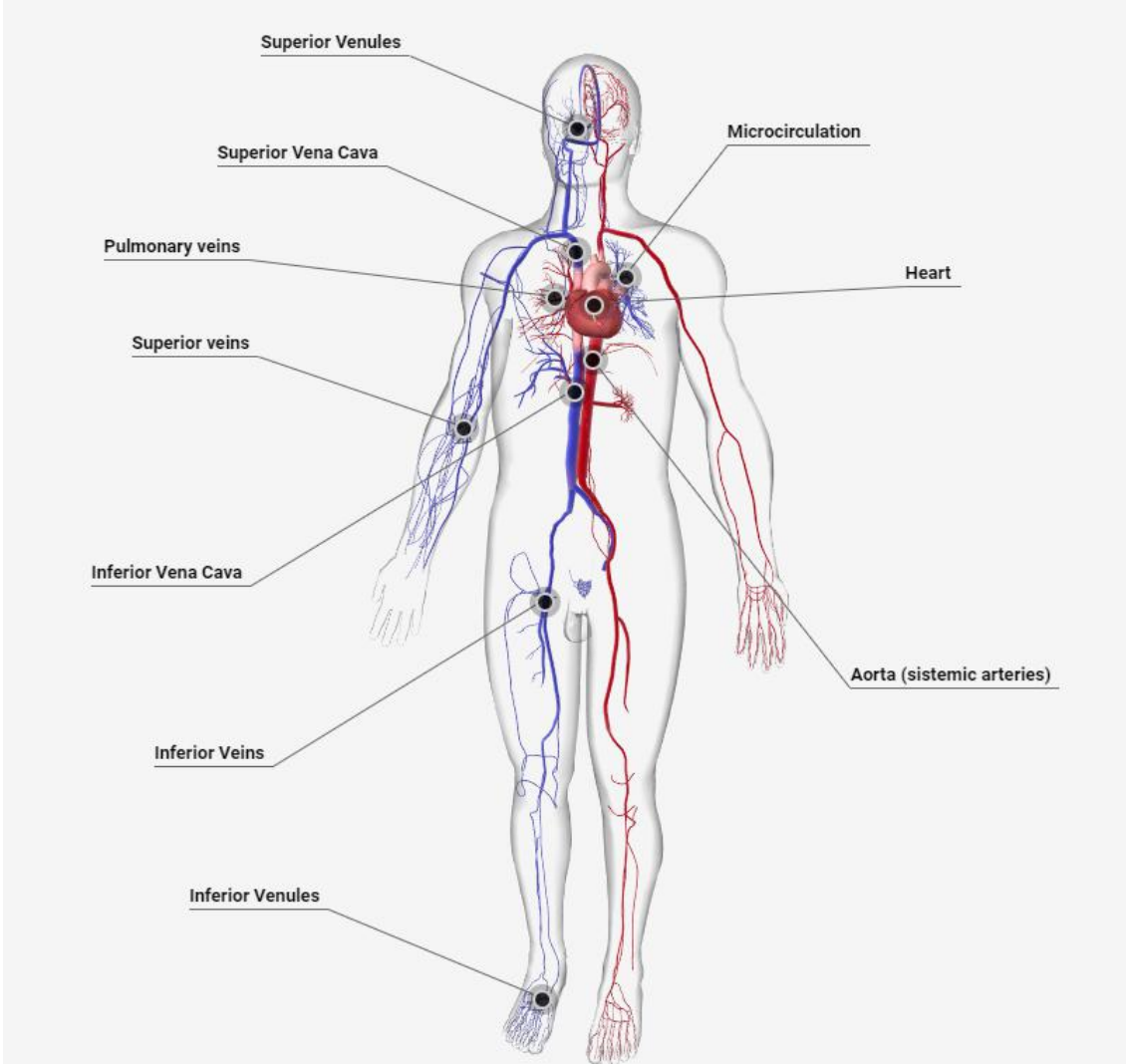
The elastance-based model is employed to model the four cardiac chambers. This model consists in normalized time-varying functions for the elastance of atria and ventricles that are the activation functions for the system. The elastance function varies over the cardiac cycle according to a exponential charge/discharge waveform (LIANG and LIU, 2005) and its form for a cardiac chamber is given by Equation 3.1.

$$E_{ch}(t) = E_A e_{ch}(t) + E_B \quad (3.1)$$

where  $E_A$  is the elastance amplitude,  $E_B$  is the baseline elastance,  $e_{ch}(t)$  is a function defined by Equation 3.2 for the atria, and by Equation 3.3 for the ventricles.

$$e(t) = \begin{cases} \frac{1}{2}[1 - \cos(\pi \frac{(t-t_c)}{T_c})] & t_{ac} \leq t \leq t_{ac} + T_{ac} \\ \frac{1}{2}[1 + \cos(\pi \frac{(t-t_r)}{T_r})] & t_{ac} + T_{ac} \leq t \leq T_0 \\ \frac{1}{2}[1 + \cos(\pi \frac{(t+T_0-t_{ar})}{T_r})] & 0 \leq t \leq t_r + T_r - T_0 \\ 0 & t_r + T_r - T_0 \leq t \leq t_c \end{cases} \quad (3.2)$$

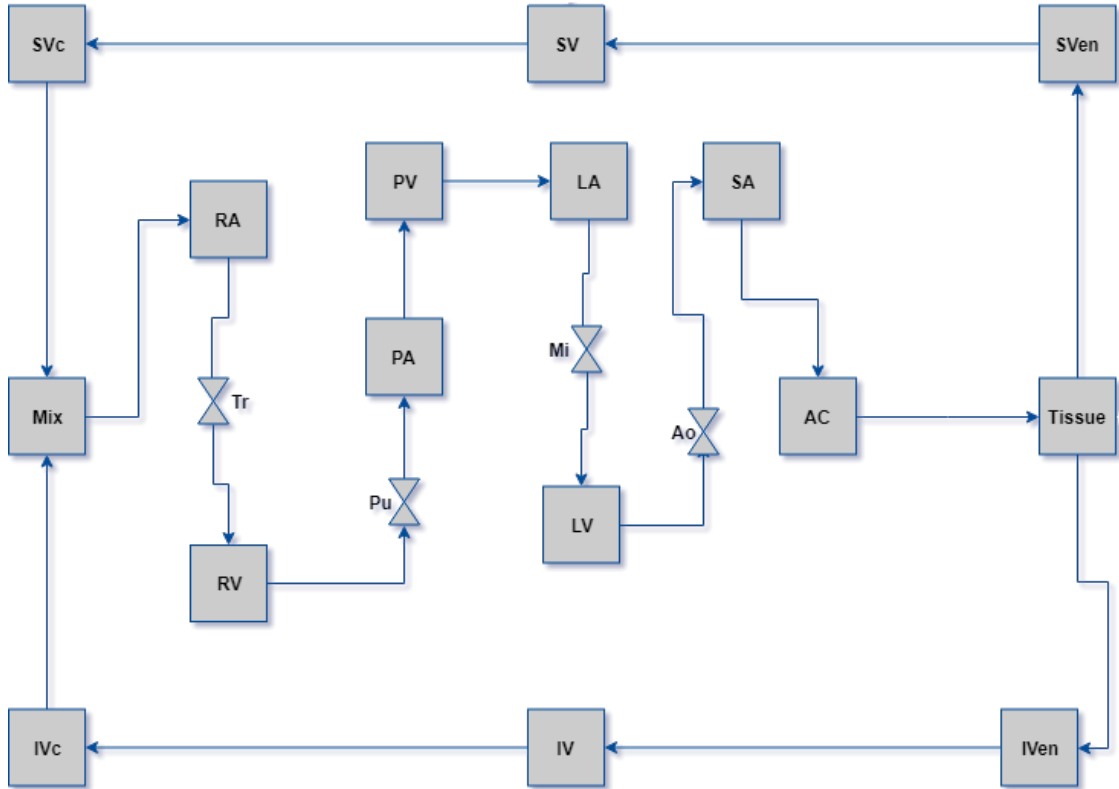




**Figure 3.1:** Image of a human and its main vessels. The image was built in such a way that the right side in the human there is just veins and in the left side, only arteries. The labels intent to give an idea of what vessels are simulated, but are not the only ones that fit in each category. Other vessels were occulted for image clearness. Generated via BioDigital (BIODIGITAL, 2019).

$$e_v(t) = \begin{cases} \frac{1}{2}[1 - \cos(\pi \frac{t}{T_{vc}})] & 0 \leq t \leq T_{vc} \\ \frac{1}{2}[1 + \cos(\pi \frac{(t-T_{vc})}{T_{vrp}})] & T_{vc} \leq t \leq T_{vc} + T_{vr} \\ 0 & T_{vc} + T_{vr} \leq t \leq T_0 \end{cases} \quad (3.3)$$

The parameters  $T_{ar}$ ,  $T_{ac}$ ,  $T_{vr}$  and  $T_{vc}$  are the duration of ventricular(v)/atrial(a) contraction(c)/relaxation(r), while  $T_0$  is the duration of the entire cardiac cycle;  $t_{ac}$  and  $t_{ar}$  refers to the instant that the atria begins to con-



**Figure 3.2:** Flowchart of the cardiovascular system from a process engineering point-of-view.

tract/relax. With this, the pressure in each chamber is given by Equation 3.4.

$$P_h(t) = E(t)(V - V_0) + S_{ch} \frac{dV}{dt} \quad (3.4)$$

where  $V_0$  represents the dead volume and  $S_{ch}$  is the viscoelasticity coefficient of the cardiac wall given by Equation 3.5,

$$S_{ch} = \alpha_{ch} |P_{in}| \quad (3.5)$$

where  $\alpha_{ch}$  is a constant. The variation of the volume of the heart chamber is given by the difference between inflow and outflow (Equation 3.6).

$$\frac{dV}{dt} = Q_{in} - Q_{out} \quad (3.6)$$

The model implementation was not so trivial in EMSO. At first, it was tried to use  $t = time - round((time - T)/T)$  but the EMSO does not deal well with the

discontinuity of the function *round* and problems with the integration appeared. It was also tried to apply some periodic function like a sine or cosine, but the number of  $n\pi$  cycles was still needed, but there was no way of finding out the “ $n$ ”, necessary for each period.

The way found to solve this problem was to use a variable that accounts for the elapsed time during the first three phases of Equation 3.2 within a heart beat, and is continuously reduced to zero during the last phase of that equation. That way, at every heart cycle, there is a variable *time* that will increase and then return to zero periodically. The piece of the code below shows how this was implemented for the atrium model.

It is important to point out that the original segmentation within a heart beat was displaced. That was necessary to maintain the system numerically stable. In the original segmentation, the last phase part took place in a very small time span, numerical instability during the integration. Time frontiers and cosines arguments had to be adjusted to maintain the representativeness of the model. Since the system has a periodic behaviour that change has no effect in the overall results.

### 3.1.2 Heart valves

To model the four cardiac valves, it is made the assumption the they do not offer resistance to the flow. Therefore, instead of using a RLC model, it is applied a RL model coupled with an ideal diode that accounts for the open/closed behavior of the valve (BLANCO *et al.*, 2010). It is important to mention that the use of the formulation for an ideal diode is a simplification, as it treats the valves behavior as binary, fully open or fully closed. However, more rigorous formulations, as the one used by BLANCO *et al.* (2010), includes a coefficient that account for the aperture of the valve orifice as a function of the opening angle of the valves. For this study, only the ideal diode model will be taken into account that is represented by Equation 3.7

$$\begin{cases} L \frac{dQ_{out}}{dt} + RQ_{out} = P_{in} - P_{out} & Q_{out} > 0 \\ Q_{out} = 0 & else \end{cases} \quad (3.7)$$

The terms “in” and “out” refer to the inlet stream and outlet stream.

### 3.1.3 Large vessels

In the compartments regarding the large vessels it is applied a RLC model, where each compartment has a resistance (R), compliance (C) and inductance (L) parameters. Equations 3.8 and 3.9 represent this model

$$L \frac{dQ_{out}}{dt} + RQ_{out} = P_{in} - P_{out} \quad (3.8)$$

$$C \frac{d}{dt}(P_{in} - P_{ex}) = Q_{in} - Q_{out} \quad (3.9)$$

where  $P_{in}$  and  $P_{out}$  are the pressures at the compartment input and output, respectively; while  $Q_{in}$  and  $Q_{out}$  refers to the flow-rate at the same points.  $P_{ext}$  is the external pressure, that can be considered constant and lumped with C.

### 3.1.4 Microcirculation

The microcirculation (or peripheral circulation) comprises the small vessels in the system: the arterioles and capillaries. The venules are not modeled here, they are rather included in the large vessels models. To account for the peripheral circulation, the RCR windkessel models used, where the capillary resistance ( $R_c$ ) is linked in series with a two-element model for the arterioles ( $R_a$  and  $C_a$  in parallel) (STERGIOPULOS *et al.*, 1992; WESTERHOF *et al.*, 2009). Equations 3.10 represents this coupling:

$$\frac{dQ_{out}}{dt} = \frac{1}{R_c R_a C_a} \left[ R_a C_a \frac{d}{dt} (P_{in} - P_{out}) + (P_{in} - P_{out}) - (R_c + R_a) Q_{out} \right] \quad (3.10)$$

According to BLANCO *et al.* (2010), this windkessel element is a link between the arterial and venous systems. Thus, the pressure input of the compartment,  $P_{in}$ , comes from the arterial side while  $P_{out}$  is the output pressure, from the venules. However, there were problems with initial conditions consistency when using Equation 3.10, therefore the model was adjusted in a way that was numerically more stable for the software to deal with. The implemented equations are

presented in Equations 3.11 and 3.12

$$C_a \frac{dP}{dt} = Q_{in} - Q_{out} \quad (3.11)$$

$$R_a Q_{in} + P_{inlet} = R_c Q_{out} + P_{out} \quad (3.12)$$

### 3.1.5 Parameters and initial conditions

Parameters were obtained from literature (BLANCO and FEIJÓO, 2011; LIANG *et al.*, 2009). Tables 3.2 to 3.5 display the parameters values for the models. The initial conditions are Table 3.6. The conditions are mostly arbitrary based in ranges for the values found in literature BETTS *et al.* (2013); BLANCO and FEIJÓO (2011); LUTTRINGER *et al.* (2003).

**Table 3.2:** Parameters values for heart chambers.

	Left Atrium	Right Atrium	Left Ventricle	Right Ventricle
$E_a$ [ $mmHg \cdot mL^{-1}$ ]	0.07	0.06	2.75	0.55
$E_b$ [ $mmHg \cdot mL^{-1}$ ]	0.09	0.07	0.08	0.05
$T_c$ [s]	0.17	0.17	0.30	0.30
$t_c$ [s]	0.80	0.80	—	—
$T_r$ [s]	0.17	0.17	0.15	0.15
$t_r$ [s]	0.97	0.97	—	—
$T_0$ [[s]	1.0	1.0	1.0	1.0
$\alpha$ [ $s \cdot mL^{-1}$ ]	0.0005	0.0005	0.0005	0.0005
$V_0$ [mL]	4.0	4.0	5.0	10.0

**Table 3.3:** Parameters values for heart valves.

	Mitral	Aortic	Tricuspid	Pulmonary
$L$ [ $mmHg \cdot s^2 \cdot mL^{-1}$ ]	0.00002	0.00005	0.00002	0.00005
$R$ [ $mmHg \cdot s \cdot mL^{-1}$ ]	0.001	0.003	0.001	0.003

## 3.2 Pharmacokinetics in a process simulator

### 3.2.1 Mass transfer model

Each model is represented by equations that describe absorption, elimination and transfer of chemicals between compartments. However, the rates depend

**Table 3.4:** Parameters values for veins and venules.

	<b>Sup.Venules</b>	<b>Inf. Venules</b>	<b>Sup.Veins</b>
$L [mmHg \cdot s^2 \cdot mL^{-1}]$	0.00001	0.00001	0.000005
$R [mmHg \cdot s \cdot mL^{-1}]$	0.14	0.04	0.03
$C [mL \cdot mmHg^{-1}]$	0.5	1.5	15.0
	<b>Inf. Veins</b>	<b>Sup. Vena Cava</b>	<b>Inf. Vena Cava</b>
$L [mmHg \cdot s^2 \cdot mL^{-1}]$	0.000005	0.000005	0.000005
$R [mmHg \cdot s \cdot mL^{-1}]$	0.009	0.0005	0.0005
$C [mL \cdot mmHg^{-1}]$	75.0	15.0	5.0

**Table 3.5:** Parameters values for other vessels.

	<b>Systemic Arteries</b>	<b>Pulmonary Veins</b>	<b>Pulmonary Arteries</b>	<b>Arterioles</b>	<b>Capillaries</b>
$L [mmHg \cdot s^2 \cdot mL^{-1}]$	0.0	0.0	0.0	0.0	0.0
$R [mmHg \cdot s \cdot mL^{-1}]$	0.0010538	0.01	0.08	0.463672	1.854688
$C [mL \cdot mmHg^{-1}]$	1.2523	80.0	4.12	0.00001	0.0

on the structure of the model, despite of the chemical's nature, that are mere parameters. The transport mechanisms of the drug through the tissue boundary layer, as well as its interaction with the membrane molecules, also influence in the concentration of a specific component in the blood stream. But since this study tries to give a more general approach for the problem, i.e., disregarding the chemical reactions, that interaction will not be dealt with in this study. The main idea is to focus on the mechanical dynamics of a component in the blood stream.

The PBPK model presented here was based on existing models in the literature (DEDON *et al.*, 2013; DI and KERNS, 2015; DIX, 2001).

Initially, a model for an intravenous bolus (IV bolus) injection was included. A bolus injection refers to a drug dose injected at once (opposing to a dose delivered by a saline solution, that is injected over a certain amount of time). As discussed before, the absorption is bypassed here. The initial step is to include a mass balance for the component X (the chemical) (Equation 3.13):

$$\frac{dm}{dt} = X_{in}Q_{in} - X_{out}Q_{out} \quad (3.13)$$

**Table 3.6:** Initial conditions of the system.

Site	$P_0$ [mmHg]	$Q_0$ [ $\frac{ml}{s}$ ]	$X_0$ [ $\frac{g}{L}$ ]
<b>Pulmonary artery</b>	8 <i>in</i>	60 <i>in</i>	0.0 <i>out</i>
<b>Pulmonary veins</b>	5 <i>in</i>	-	0.0 <i>out</i>
<b>Microcirculation</b>	50 <i>in</i> , 5 <i>out</i>	2 <i>in</i>	0.0 <i>out</i>
<b>Superior Venules</b>	-	-	0.0 <i>out</i>
<b>Inferior Venules</b>	-	-	0.0 <i>out</i>
<b>Superior veins</b>	3 <i>in</i>	12 <i>in</i>	0.0 <i>out</i>
<b>Inferior veins</b>	3 <i>in</i>	13 <i>in</i>	0.0 <i>out</i>
<b>Superior Vena Cava</b>	3 <i>in</i>	12 <i>in</i> , 10 <i>out</i>	0.0 <i>out</i>
<b>Inferior Vena Cava</b>	3 <i>in</i>	11 <i>in</i> , 10 <i>out</i>	0.0 <i>out</i>
<b>Systemic Arteries</b>	-	0 <i>in</i>	0.0 <i>out</i>
<b>Right Atrium</b>	-	-	0.0 <i>out</i>
<b>Left Atrium</b>	-	-	0.0 <i>out</i>
<b>Right Ventricle</b>	-	10 <i>in</i>	0.0 <i>out</i>
<b>Left Ventricle</b>	-	10 <i>in</i>	0.0 <i>out</i>
<b>Tissue</b>	-	-	0.0 <i>out</i>

but,

$$m = X_{out}V \quad (3.14)$$

$$\frac{dm}{dt} = \frac{d(X_{out}V)}{dt} \quad (3.15)$$

expanding Equations 3.14 and 3.15:

$$\frac{dm}{dt} = X_{out} \frac{dV}{dt} + V \frac{dX_{out}}{dt} \quad (3.16)$$

From the linear moment balance of the system:

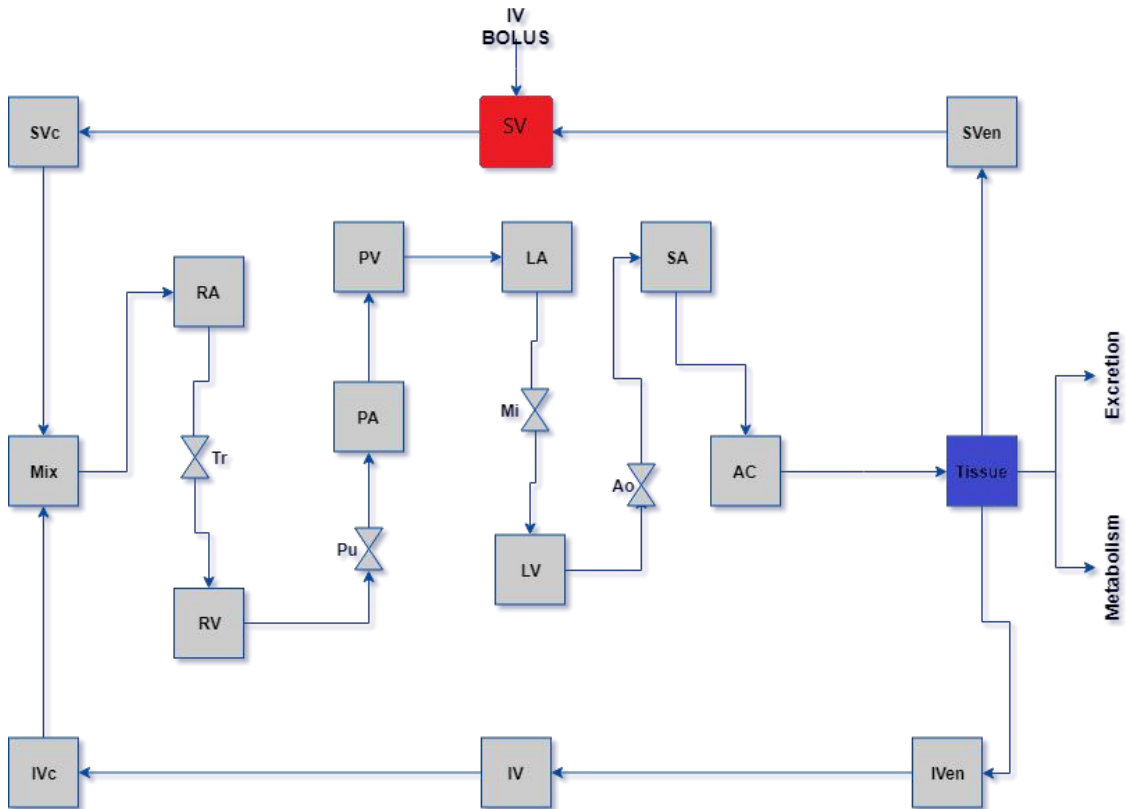
$$dV = CdP_{in} \quad (3.17)$$

$$V - V_0 = C(P_{in} - P_{in,0}) \quad (3.18)$$

and thus:

$$X_{out}C \frac{dP_{in}}{dt} + [V_0 + C(P_{in} - P_{in,0})] \frac{dX_{out}}{dt} = X_{in}Q_{in} - X_{out}Q_{out} \quad (3.19)$$

With that balance in hands, it can now be inserted into all the other compartments on the previous simulation. However, changes have to be made in the model for the compartment where the drug is injected and for the compartment where the drug is cleared from the blood system. It is assumed the **superior veins** for the injection and the withdraw of chemical occurs only at the capillaries level, as discussed before. Figure 3.3 illustrates the process flowchart with the drug injection and withdraw.



**Figure 3.3:** Flowchart of the cardiovascular system with administration route and withdraw of a drug.

Equations 3.20, 3.21 and 3.22 are the model input for the superior veins compartment. The new term  $X_{iv}Q_{iv}$  is the amount of drug that enters the blood-stream at that site by intravenous injection:

$$L \frac{dQ_{out}}{dt} + RQ_{out} = P_{in} - P_{out} \quad (3.20)$$



$$C \frac{dP_{in}}{dt} = Q_{in} - Q_{out} + Q_{iv} \quad (3.21)$$

$$X_{out} C \frac{dP_{in}}{dt} + [V_0 + C(P_{in} - P_{in,0})] \frac{dX_{out}}{dt} = X_{in} Q_{in} - X_{out} Q_{out} + X_{iv} Q_{iv} \quad (3.22)$$

Now, for the withdraw, a kidney and liver compartment was added, where the drug was removed by metabolism and excretion. According to DIX (2001), elimination and metabolism can be modeled as a first order processes. (Equations 3.23 and 3.24):

$$V_l \frac{dX_l}{dt} = Q_l(X_{in} - X_{out}) + K_{met} X_{out} V_l \quad (3.23)$$

$$V_k \frac{dX_k}{dt} = Q_k(X_{in} - X_{out}) + K_{exc} X_{out} V_k \quad (3.24)$$

where  $V$  is the volume of the liver (l) or kidney (k) and  $K$  is the first order rate constant [1/s] for excretion an metabolism.  $X_{out}$  is the concentration of drug in the blood that leaves the tissue and goes back to the blood stream, while  $X_l$  and  $X_k$  are the concentration at the tissue.  $Q_l$  and  $Q_k$  are the blood perfusion of the organ. The drug concentration can be expressed at the tissue as a fraction of the concentration in the blood that perfuses a specific tissue, and depend on the affinity between the chemical and the tissue, that is called plasma-tissue partition coefficient. The partition coefficient ( $\beta$ ) is represented by Equation 3.25:

$$\beta_k = \frac{X_t}{X_{out}} \quad (3.25)$$

Equations 3.27 and 3.26 are the result of replacing Equation 3.25 in Equations 3.24 and 3.23:

$$V_k \beta_l \frac{dX_{out}}{dt} = Q_k(X_{in} - X_{out}) + K_{exc} X_{out} V_k \quad (3.26)$$

$$V_k \beta_l \frac{dX_k}{dt} = Q_k(X_{in} - X_{out}) + K_{exc} X_{out} V_k \quad (3.27)$$

where  $\beta_i$  is the partition coefficient plasma-tissue for each organ.

Note that the withdraw term in Equation 3.24 and 3.23 are modeled the same, as a first order process, but observe that excretion is a mass transport process, while metabolism involves chemical reactions, and thus, can also be modeled by Michaelis-Menten kinetics (Equation 3.28).

$$r_{met}V_{met} = \frac{v_m X_{out}}{K_m + X_{out}} V_{met} \quad (3.28)$$

where  $v_m$  would be the maximum rate of reaction and  $K_m$  the Michaelis constant.

### 3.2.2 Parameters

Tables 3.7 and 3.8 display the additional parameters used for the simulations.

**Table 3.7:** Parameters for elimination at the tissues.

Tissue	Parameter			
	$K$ [ $\frac{1}{s}$ ]	$\beta$	$V$ [mL]	$Q$ [ $\frac{mL}{s}$ ]
<b>Kidney</b>	0.001967 <sup>[1]</sup>	2.73 <sup>[2]</sup>	308 <sup>[2]</sup>	20.58 <sup>[2]</sup>
<b>Liver</b>	0.00257 <sup>[1]</sup>	4.46 <sup>[2]</sup>	1800 <sup>[2]</sup>	27.08 <sup>[2]</sup>

[1] VANDEGINSTE *et al.* (1998)

[2] LUTTRINGER *et al.* (2003)

**Table 3.8:** Initial volume parameter for blood vessels.

$V_0$ [mL] <sup>[1]</sup>	<b>Pulmonary arteries</b>	<b>Pulmonary veins</b>	<b>Systemic Arteries</b>	<b>Superior Veins</b>
	100	350	550	750
	<b>Inferior Vena Cava</b>	<b>Superior Vena Cava</b>	<b>Inferior Venules</b>	<b>Superior Venules</b>
	370	400	370	500
	<b>Inferior Veins</b>	<b>Arterioles</b>		
	800	450		

[1] YOUNG (2010) Calculated based in blood percentage distribution for an average human (70kg)

## 3.3 EMSO and machine setup

A personal computer was used to carry out all simulations. Software and hardware characteristics are listed in Table 3.9.

**Table 3.9:** Hardware and Software configurations.

<b>Software</b>	
<b>EMSO version</b>	Academic beta version 0.10.9 win32
<b>DAE solver</b>	dasslc

<b>Hardware</b>	
<b>Operational System</b>	Windows 10 Home Single Language x64bits
<b>Processor</b>	Intel Core™ i5
<b>RAM</b>	8.00 GB

# Chapter 4

## Results and Discussion

### 4.1 Model implementation checking (without mass transfer)

For the presented cardiovascular system the simulations were run in a Intel i5 processor with 8GB of RAM and took an average 40 seconds to run 15 cycles and no processor cluster was necessary.

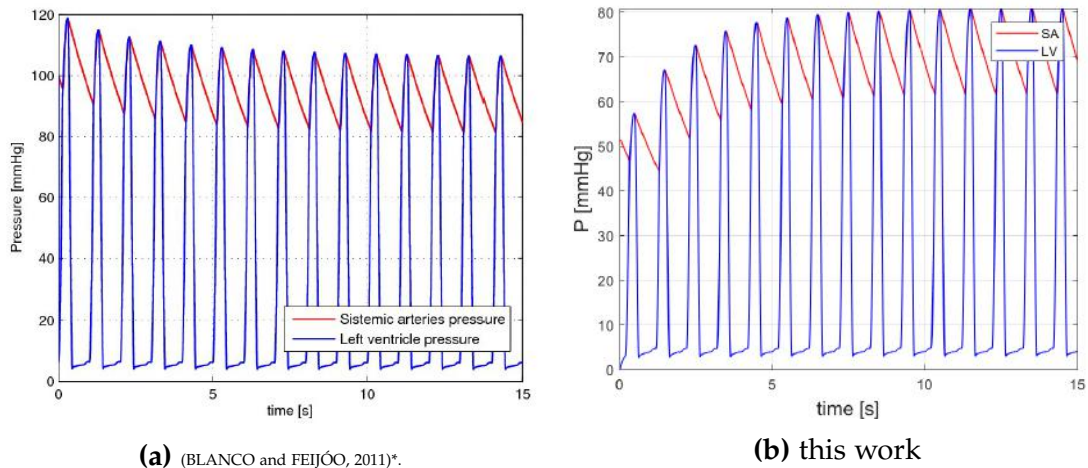
BLANCO and FEIJÓO (2011) presented results for the 0D model discussed here. Therefore, all results obtained were compared to those presented by these authors.

As mentioned in Chapter 3, some adjustments were made in the model in order to improve numerical efficiency, and one of them was the shift in the order of the cardiac cycle steps. As a consequence, this work results are displaced with respect to those found in BLANCO and FEIJÓO (2011). Ergo, for the sake of visual comparison, the initial points in the plot results from this study were shifted in order to match the starting point in the original results.

It is important to point out that there was no concern whatsoever, in this section, to discuss the physiological meaning of all obtained results. Some context will be provided, however, on the importance and applications of some results. Nonetheless, the main idea here is to provide verification for the implementation of the mathematical model in the software employed (EMSO), by comparing it to others already validated results, as well as discuss modeling peculiarities. Once it is demonstrated that the model implementation in the EMSO simulator is correct, then the inclusion of the pharmacokinetics models can proceed.

It is important to mention that the results used for the plots were not selected from the beginning of the simulation. The data was extracted after the system enters the cyclic steady state. In Figure 4.1, where the pressure *vs.* time data is plotted over all 15 cycles, is visible the timespan for the system to get to cyclic

steady state. The data obtained from the period before reaching the cyclic steady state has no physiological meaning, but rather is a measure of the quality of the system set-up, e.g., quality of initial conditions. The results from simulations are presented in Figures 4.1 to 4.5.



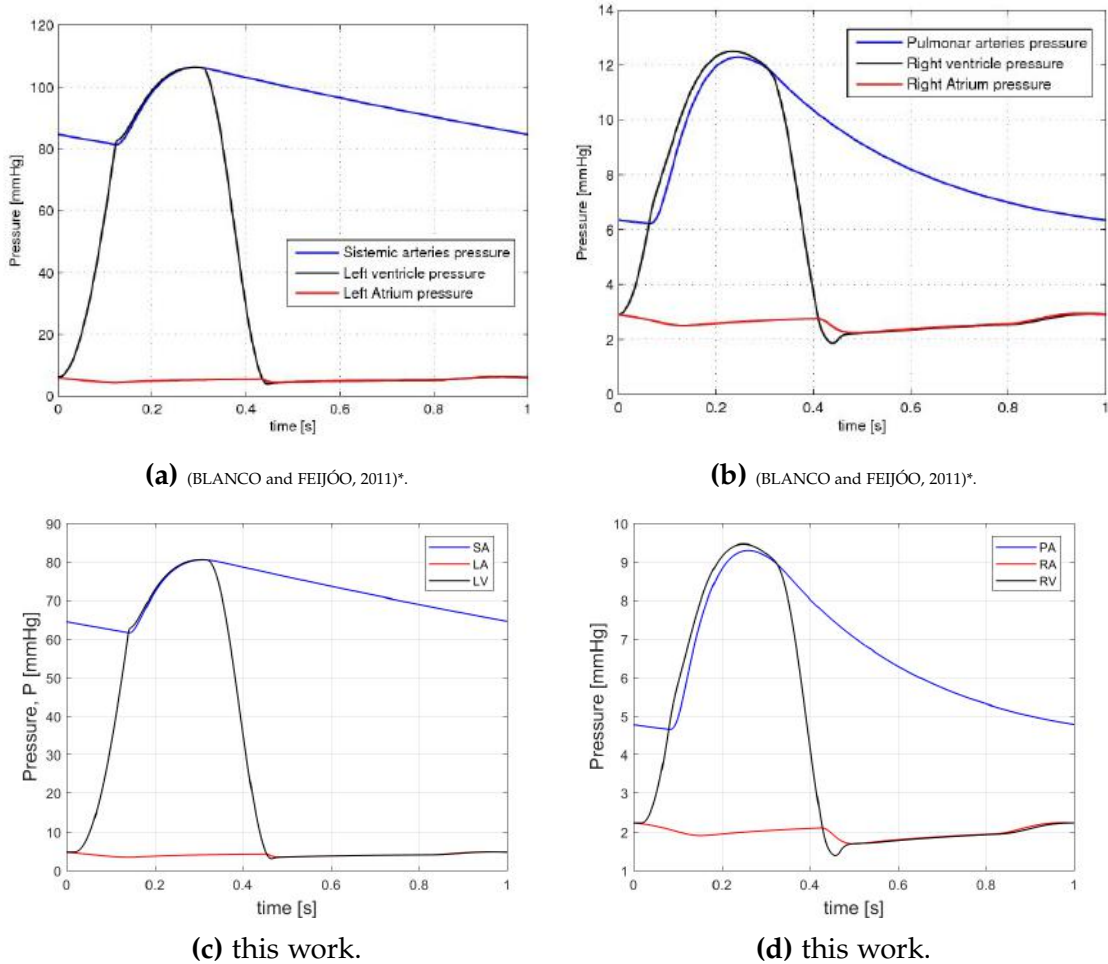
**Figure 4.1:** Comparison between literature and obtained results for the variation of the pressure with time in all 15 cycles, for the systemic arteries (SA) and left ventricle (LV). Leftmost plot (a) is duplicated from literature, while rightmost plot (b) is a result from this study. \*With permission from the authors.

Also, it is relevant to explain that there was no access to real data from patients and initial conditions used for the simulations in literature were not found. However, as the main idea was to analyze the system in a qualitative fashion, those values were not crucial. Therefore, rough averages were used for initial conditions based on literature (LIANG *et al.*, 2009).

Figure 4.2 display the profiles for the pressure variation with time for the left part of the heart (systemic arteries (SA), left atrium (LA), left ventricle (LV)) and right part of the heart (pulmonary veins (PV), right atrium (RA) and right ventricle (RV)) from the literature and the current study. Figure 4.4 also presents pressure *vs.* time, but for other sites (LA, PV, RA, SVC and IVc). Figure 4.3 illustrates the flow that passes through the heart valves in a cardiac cycle and Figure 4.5 depicts the elastance function of the heart chambers *vs.* time. Observe that the close completely after the ventricle systole, when the mitral and tricuspid valves permit some backflow during ventricle systole. An increase in that backflow is a sign of heart disease. The peaks in flow through mitral and tricuspid match atrial systole, whilst the peak for pulmonary and aortic valve matches ventricle systole.

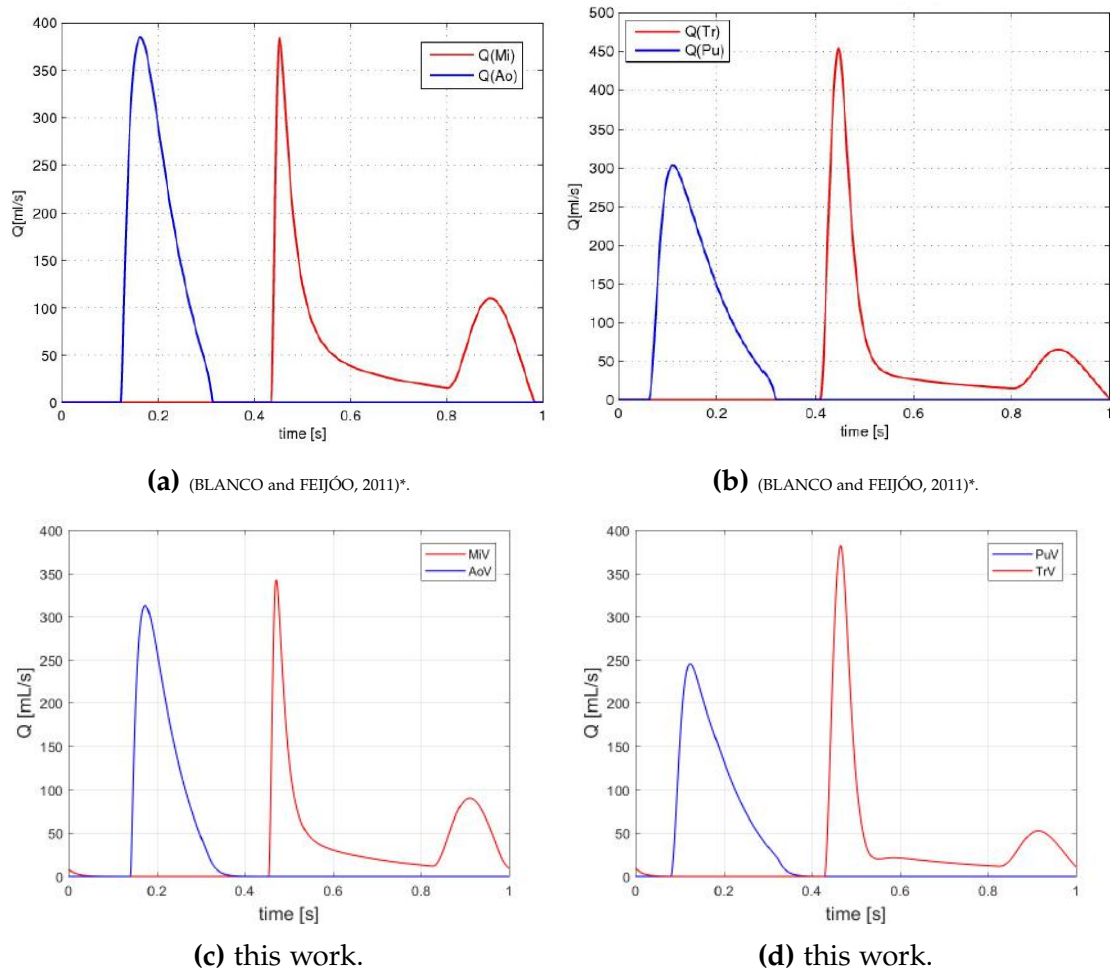
These results are an example that the variation profile was replicated for all variables, but the values were, often, not the same. That is expected, since the conditions were arbitrated in this study. But the variation profile does not

depend on the initial conditions, but is rather a function of the parameters for the compartments. These parameters were acquired from BLANCO and FEIJÓO (2011), thus, it was expected that those profiles would match the ones found in literature. Therefore, from a qualitative point of view, the model successfully returns representative results of the cardiovascular system.



**Figure 4.2:** Comparison between literature and obtained results for the variation of the pressure with time. Leftmost plots (a) and (c) depict the left part of the heart (systemic arteries (SA), left atrium (LA) and left ventricle (LV)). Rightmost plots (b) and (d) depict the right part of the heart (pulmonary veins (PV), right atrium (RA) and right ventricle (RV)). (a) and (b) are duplicated from literature, while (c) and (d) are results from this study. \*With permission from the authors.

Figure (4.6) displays the pressure variation in left and right ventricles *vs.* the volume of the chamber and Figure (4.7) illustrates how the volume of the heart chambers varies in time. Notice that the volume of the chambers never reaches zero. That is due to the fact that not all the blood present in heart chambers is pumped out. The ratio between the volume of blood during diastole (flow in) and during systole (pump out) is called the ejection fraction (EJ). The ventricles ejection fractions is a important parameter for physicians to evaluate

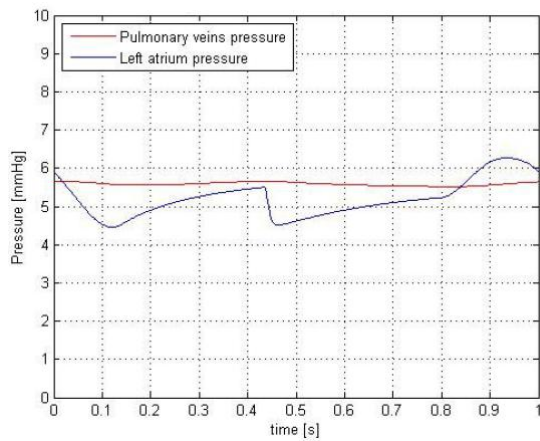


**Figure 4.3:** Comparison between literature and obtained results for the variation of the flow with time. Leftmost plots (a) and (c) depict the valves on the left part of the heart (mitral valve (MiV) and aortic valve (AoV)). Rightmost plots (b) and (d) depict the valves on the right part of the heart (pulmonary valve (PuV) and tricuspid valve (TrV)). (a) and (b) are duplicated from literature, while (c) and (d) are results from this study. \*With permission from the authors.

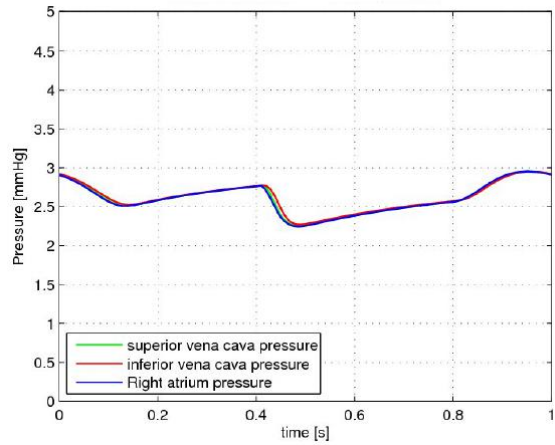
heart function and treatment development.

As mentioned before, it was not possible reproduce the exact same conditions that led to those results found in literature, although, from a qualitative point of view, all simulation were acceptable, as they can describe/predict the system's outcome in all aspects. A more thorough investigation for a realistic initial set-up for the system could bring about representative quantitative results. Anyhow, since this would vary from patient to patient, a qualitative analysis was sufficient to validate the methodology.

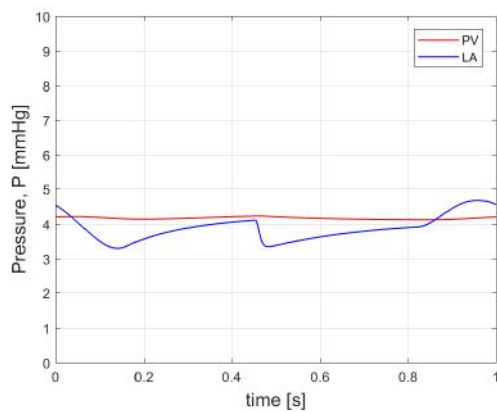
From all the preceding results, it is possible to conclude that the mathematical model was successfully implemented in the EMSO simulator and the obtained results were satisfactory and adequately reproduce literature results for all vari-



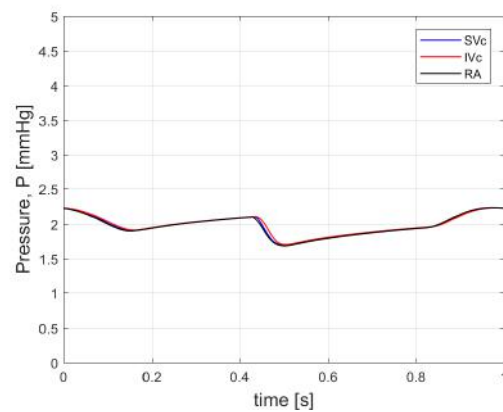
(a) (BLANCO and FEIJÓO, 2011)\*.



(b) (BLANCO and FEIJÓO, 2011)\*.



(c) this work.



(d) this work.

**Figure 4.4:** Comparison between literature and obtained results for the variation of the pressure with time. Leftmost plots (a) and (c) depict the left part of the heart (pulmonary veins (PV), left atrium (LA)). Rightmost plots (b) and (d) depict the right part of the heart (right atrium (RA), superior vena cava (SVC) and inferior vena cava (IVc)). (a) and (b) are duplicated from literature, while (c) and (d) are results from this study. \*With permission from the authors.

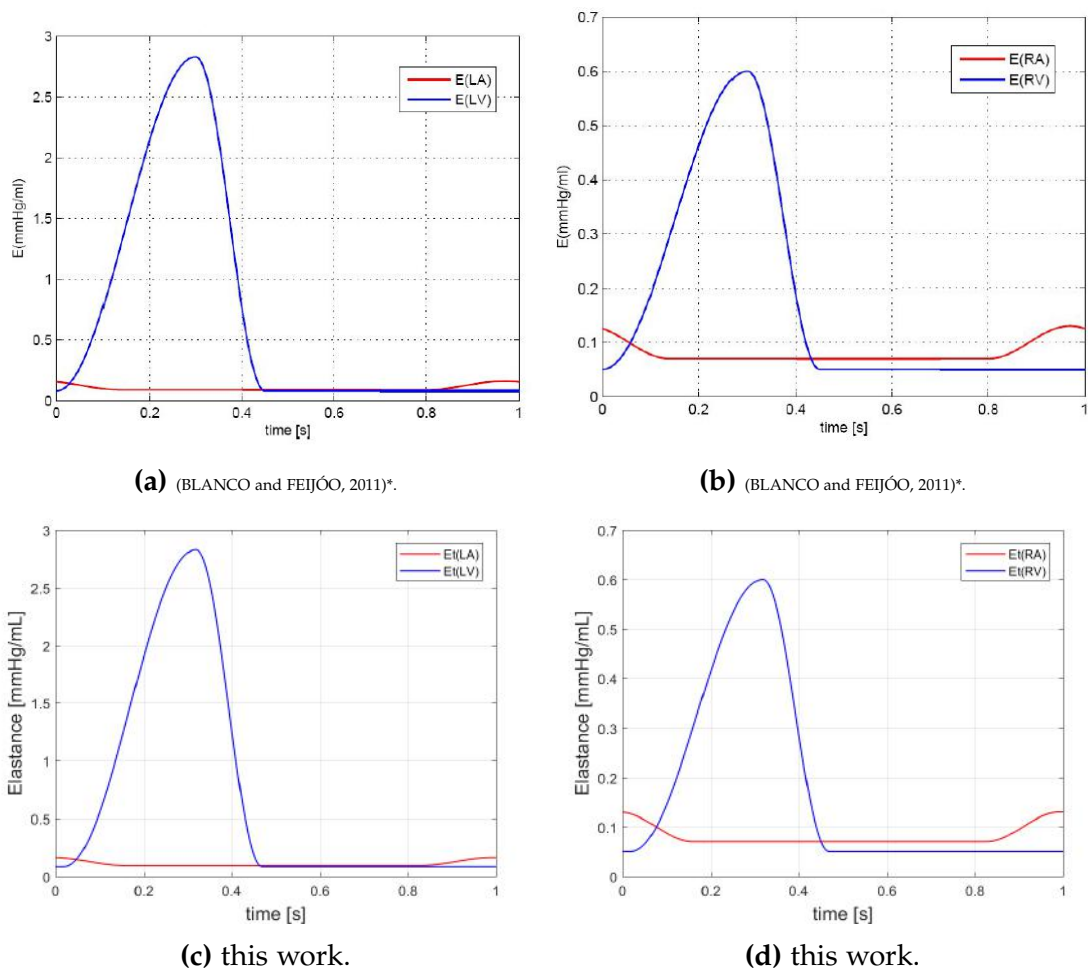
ables in the model.

## 4.2 PBPK results

For the PBPK simulations certain conditions were assumed:

- The simulated drug is hypothetical;
- The administration route is an IV bolus with the injection site being the superior veins;
- All drug withdrawals (plasma to tissue) are carried out at the level of capillaries;

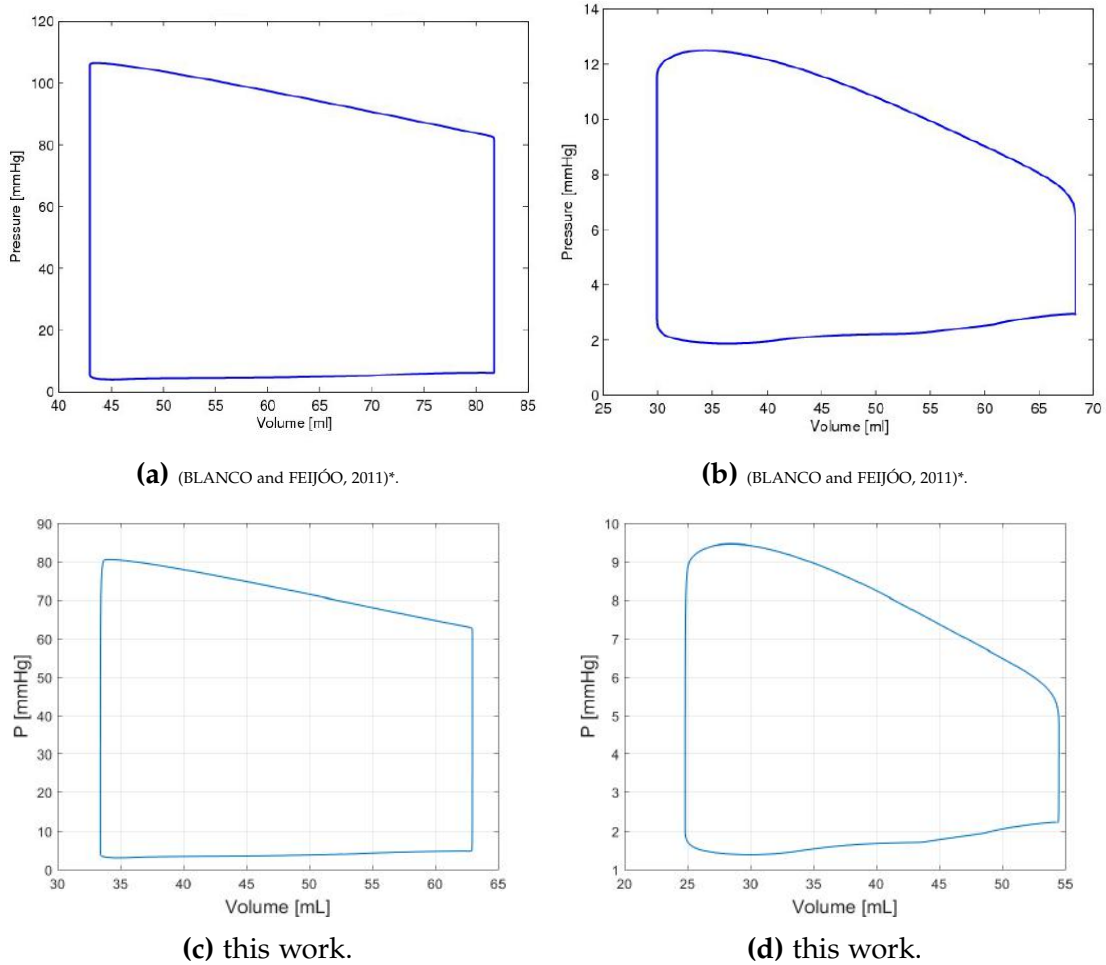




**Figure 4.5:** Comparison between literature and obtained results for the variation of the elastance ( $E_t$ ) of a cardiac chamber with the time. Leftmost plots (a) and (c) depict the left part of the heart (left atrium (LA) and left ventricle (LV)). Rightmost plots (b) and (d) depict the right part of the heart (right atrium (RA) and right ventricle (RV)). (a) and (b) are duplicated from literature, while (c) and (d) are results from this study. \*With permission from the authors.

- Drug withdraw is only for elimination;
- Elimination comprises only excretion at kidneys and metabolism at liver;
- There is no drug reabsorption (tissue to plasma);
- There is no macromolecular binding;
- Drug distribution is perfusion-rate-limited (diffusion is rapid, therefore negligible);
- There is no drug in the system before the injection, therefore all  $X_0 = 0$ .

For the presented cardiovascular system, the simulations were run in a Intel i5 processor with 8GB of RAM and took an average of 8 minutes to run 500

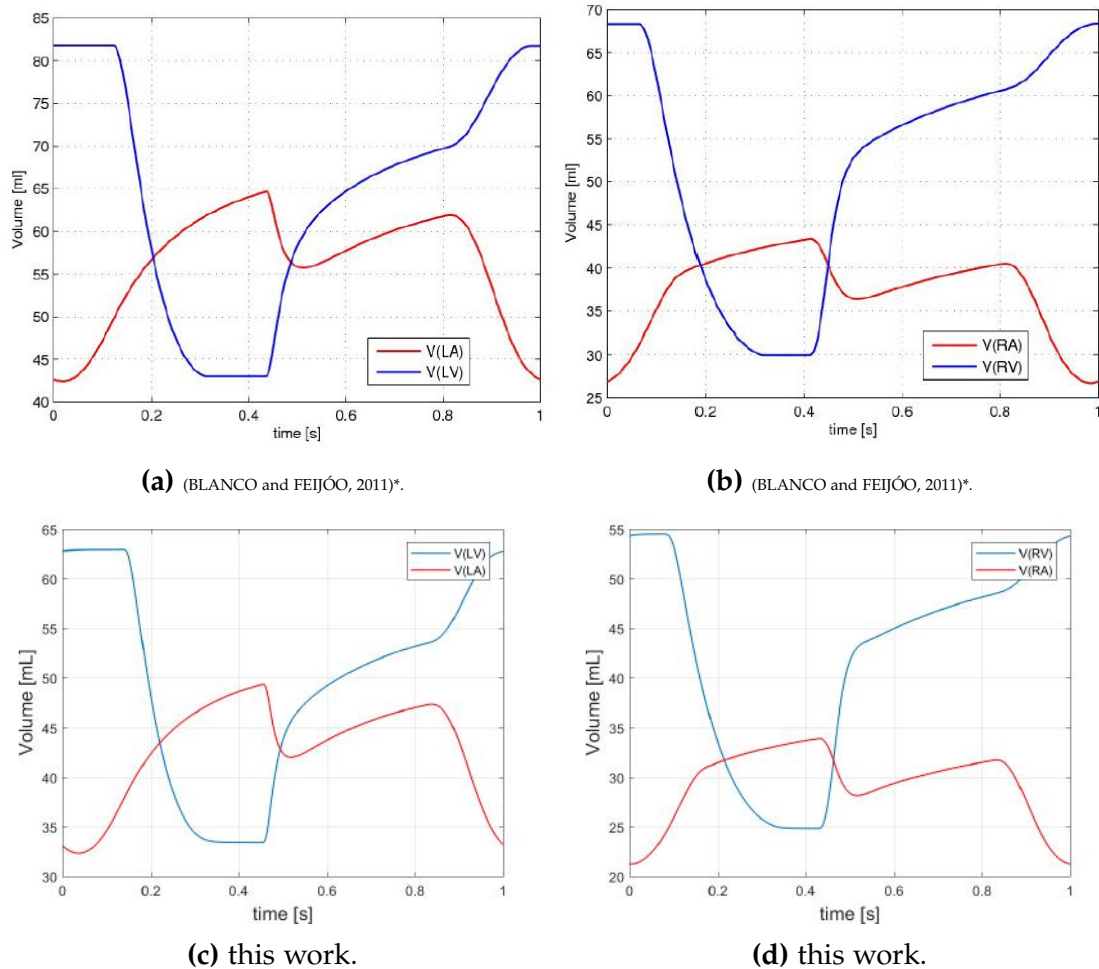


**Figure 4.6:** Comparison between literature and obtained results for the variation of the pressure of a cardiac chamber with the volume of the chamber. Leftmost plots (a) and (c) depict the left part of the heart (left atrium (LA) and left ventricle (LV)). Rightmost plots (b) and (d) depict the right part of the heart (right atrium (RA) and right ventricle (RV)). (a) and (b) are duplicated from literature, while (c) and (d) are results from this study. \*With permission from the authors.

cycles and an average of 30 min for the 5,000 cycles. No processor cluster was necessary.

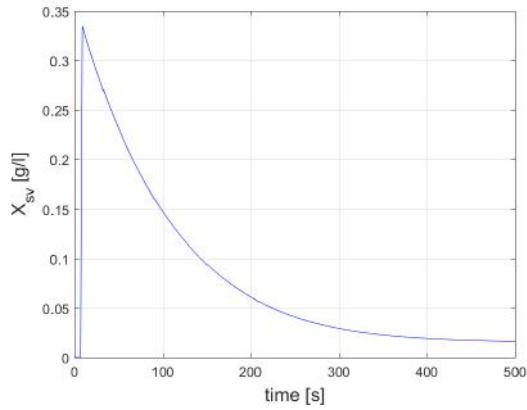
In order to consider that the distribution is perfusion driven, the concentrations of chemical in the intra and extracellular spaces are considered in equilibrium, and therefore, the tissue can be represented as a single compartment (DIX, 2001). The kidney and liver were modeled in this single compartment.

The input parameter was an injection of  $Q_{injection} = 2.5\text{mL/s}$  and  $X_{injection} = 50\text{g/l}$  during 2 seconds, starting at 7s from the beginning of the simulation. The results for the variation of the concentration with time for the injection compartment (SV), the microcirculation (AC) and elimination (by metabolism and excretion) are represented in Figures 4.8, 4.9 and 4.10.

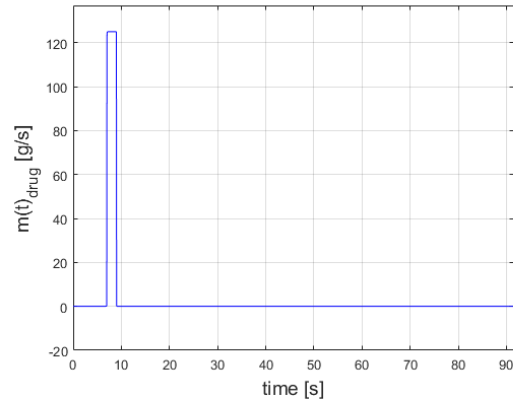


**Figure 4.7:** Comparison between literature and obtained results for the variation of the volume of a cardiac chamber with time. Leftmost plots (a) and (c) depict the left part of the heart (left atrium (LA) and left ventricle (LV)). Rightmost plots (b) and (d) depict the right part of the heart (right atrium (RA) and right ventricle (RV)). (a) and (b) are duplicated from literature, while (c) and (d) are results from this study. \*With permission from the authors.

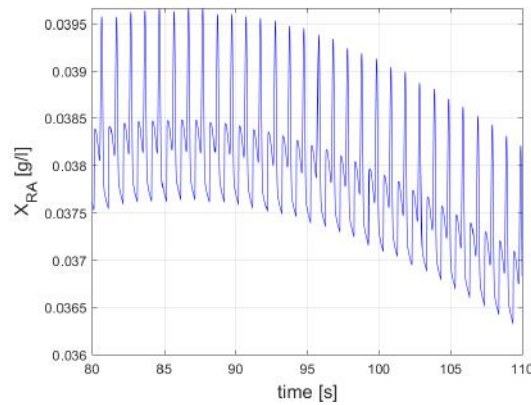
The results for de concentration at the injection site (Figure 4.8) and at the level of capillaries (Figure 4.9) were within the expected. Note that the concentration at the injection site peaks up around seven seconds, but soon starts to decrease once the drug input ceases. Comparing to the microcirculation, the increase in the concentration only will start around 20s. That delay is expected, since they are not contiguous compartments. Also, it is observable, at Figure 4.8c, that the dynamics for the concentration is considerably slower than the dynamics for the cyclic flow. This can be very useful, after all the interest in this study is to understand not only “if” the drug will reach its target tissue, but also “when”. Usually, pharmacokinetics models rely on initial and final concentration of a xenobiotic in a given tissue, and also how much time its concentration



(a)  $X_{sv}$  vs. time.

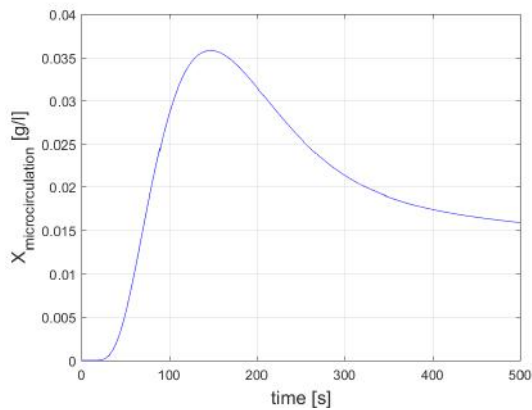


(b)  $dm/dt$  vs. time.

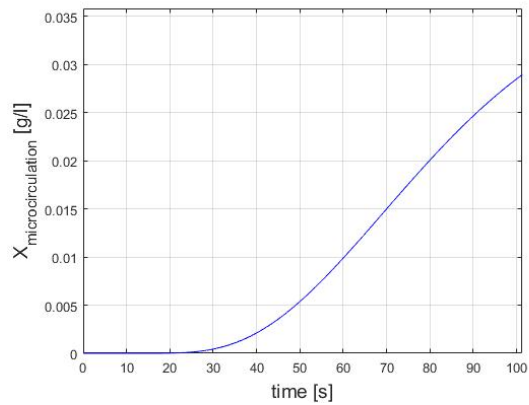


(c)  $X$  vs. time. at right atrium

**Figure 4.8:** Results for the (a) variation of concentration ( $X$ ) vs. time at the injection site.; (b) the pulse for the injection (500 cycles and (c) the right atrium  $X$  vs.  $t$  profile.).



(a)

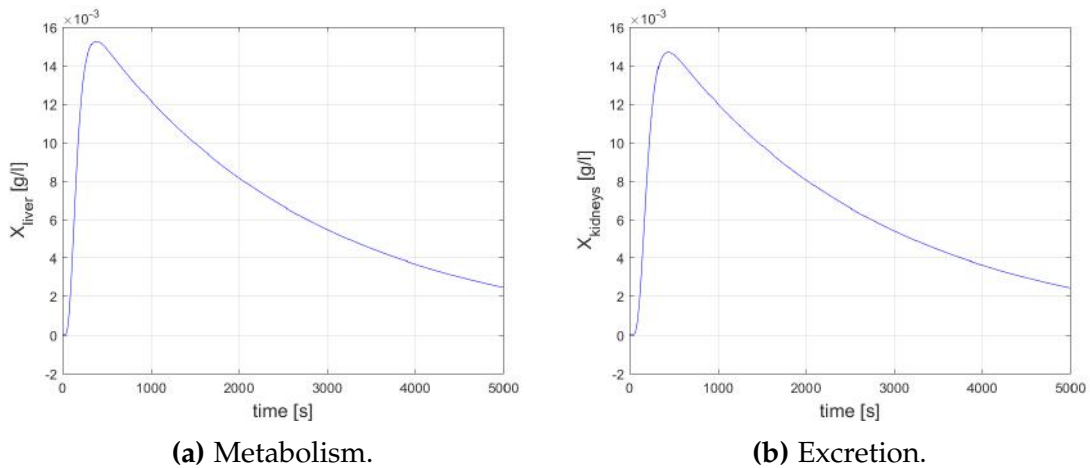


(b)

**Figure 4.9:** Results for the variation of concentration ( $X$ ) vs. time at the level of capillaries. (a) depicts the whole simulation (500 cycles), while (b) is a close-up to the initial seconds.

will stay above a given threshold, treating it similar to a function of state. With this, the “IF” question can be answered, but there are a lot of parameters that derive from there, and most likely will depend on the path that the chemical took there. To make this more clear, it is interesting to look at the partition coefficient parameter. If a drug is administered orally and a urine sample from the patient is tested and find low to zero concentration of that drug there, does that mean that the partition coefficient of the drug is low relatively to the kidneys tissue? Not necessarily. If the partition coefficient of the chemical relative to another tissue is high enough, its bioavailability will be low, and it might not reach kidneys; or it was not yet absorbed enough by the gastrointestinal tract to be detectable. That is why the “when” question is important too. The goal is to know “if” a chemical will reach its target tissue, but also when and what will be its concentration by then. PBPK models are proven representative in many cases, but coupling with a circulation dynamics model could be a way of enhancing its applicability and efficiency.

Now that it was discussed the importance of transport equations in a drug kinetics model, now, it can be discussed the elimination dynamics. Figures 4.10a and 4.10b illustrate the results. Note that a 5,000 cycle simulation was necessary to view almost the whole profile of the drug withdraw.



**Figure 4.10:** Results for the variation of concentration ( $X_{excretion}$ ) 4.10b and ( $X_{metabolism}$ ) that returns to the system.

It is important to point out that for this model, there is no "sink" for the elimination stream, that is, the point is not to monitor how much is flowing out, but how much is still on the system. Note that the  $X_{kidneys}$  and  $X_{liver}$  are the outlet streams from the tissue compartment, and go back to blood stream, but that is not due to reabsorption tissue/plasma process, but rather is the amount of drug that did not reach the organs and remained free at the plasma. Observe that a reabsorption would imply another transport constant and that the value

for  $X_{out}$  at kidneys or liver is merely  $X_{out} = [X_{in}Q_{in} - (X_{elim}Q_t)]/Q_{out}$ , where  $Q_i$  is the flow to the tissue.

There are several important pharmacokinetics parameters that can be derived using the result aforementioned.

The first, bioavailability (F), is a measure of the fraction of blood that reaches the blood stream unchanged (by metabolism or protein binding), and is calculated using the area under the curve (AUC) in plot  $X$  vs  $time$  4.11a. For this study, the availability will always be one, since the administration is directly to bloodstream. For the other routes, the chemical will have to undergo absorption, then its AUC will be smaller ( $AUC_{ab}$ ):

$$F = \frac{AUC_{ab}}{AUC_{iv}} \quad (4.1)$$

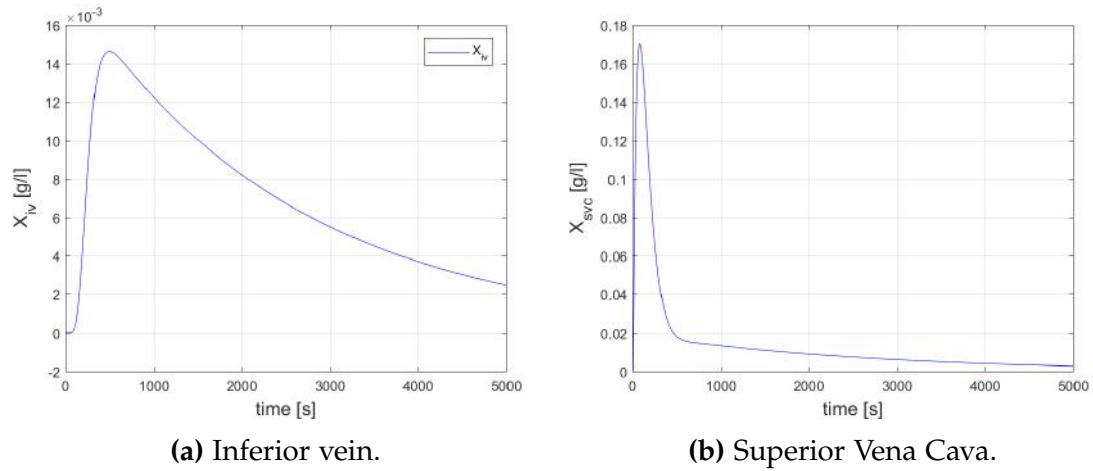
The second is clearance, a measure of how fast a chemical is removed from the circulation. The clearance is determined for the tissue that eliminates the drug, mainly kidneys and liver, referred as renal and hepatic clearance. Skin, saliva and lungs are too elimination routes, but the clearance is very small, and it is not often used. Liver clearance includes biliary extraction, when compounds are removed by bile and excreted into the intestines to be eliminated by feces VANDEGINSTE *et al.* (1998). Since the biliary extraction involves a passive or active transportation (as in any absorption), that was not considered in this study.

Clearance is determined by the blood flow to the organ and the extraction ratio (E)  $C_l = Q * E$ , the latter will depend on the composition of the drug. From plots in Figure (4.10) it is possible to obtain the renal clearance and hepatic clearance of the drug. Since the administration site was intravenous, thus the bioavailability is equal to one, then the renal and hepatic clearance can be calculated based on the area under the curve (AUC) and the intravenous dose (Equation 4.2). Often, the term systemic clearance is used referring to the sum of all specific clearances VANDEGINSTE *et al.* (1998).

$$C_l = \frac{DOSE}{AUC} \left[ \frac{mL}{min \cdot kg} \right] \quad (4.2)$$

Another important parameter is the drug half-life ( $t_{1/2}$ ) in the system. This parameter is a measure of the time that takes to a drug to reduce to half its concentration in the circulation. It can be inferred, for example, from a quick observation to Figure 4.11a, for the inferior veins, that for this hypothetical com-

pound, the half life is around 40 min (2,400s). The half-life is a important parameter that is usually used for physicians to determine, e.g., when the drug has to be redosed to maintain a therapeutic concentration DIX (2001).



**Figure 4.11:** Comparison between the results for the variation of concentration (X) for the inferior veins and the superior vena cava.

Note that the half life for the superior vena cava, Figure 4.11b, is considerably lower than that of the inferior veins. That can be related the partition coefficients ( $\beta$ ), as well as the disposition of the system in this study (3.3), since the vena cava is right after the injection point and "before the tissues, and the inferior vein right after the tissue. But that is also an interesting result of the dynamics of the system, a pure pharmacokinetic model would not take this dynamics into account. The drug concentrations varies from site to site, and the administration route can be determined based on these results as well.

# Chapter 5

## Conclusions and Suggestions

This study presented a new approach for the modeling of the cardiovascular system and drug delivery within it, employing the process simulator EMSO. The model for the cardiovascular system was a macroscopic (0D) model that does not include space variables (only time-variant). The results were divided into two parts, where the first part provided a model implementation checking and the second part included a physiological based pharmacokinetic model (PBPK), in order to account for drug delivery. The main conclusions for the first part were:

- The 0D model was able to reproduce the results found in literature for all compartments, providing representative qualitative profiles for the variables and, thus, enabling it to serve as a flow model for the coupling between circulation and pharmacokinetics.;
- A quantitative reproduction was not achieved due to the fact that it was not possible to find a complete data set for the initial conditions of a real system from literature.

For the pharmacokinetics/transport coupling, the main points were:

- The implementation of the PBPK model was successful and the concentrations profile obtained were according to what was expected physically and from comparisons with literature.
- From the results were able to derive relevant parameters from a physiological point-of-view.

The major setback faced during the study was the difficulty to determine a consistent set of initial conditions for the differential-algebraic equations (DAE). Some manipulations were made in order to reduce the structural index, therefore, aiding the numerical solution. Additional analysis in order to develop an

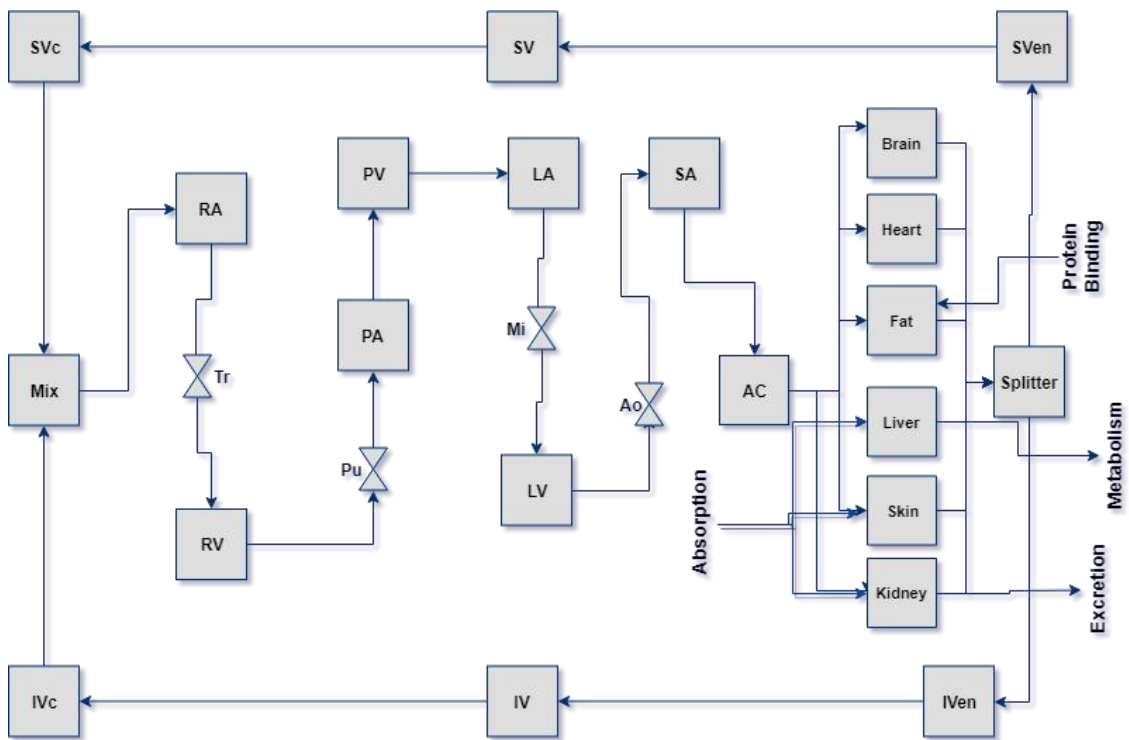


algorithm or system that can always select consistent initial conditions would help further developments for the approach.

Finally, EMSO was a good choice for a system like that, mainly concerning implementation. Since the software is object-oriented, it is easier to implement equations and manipulate them when compared to other simulators, and the index analysis carried out automatically by the software helped very much to write a consistent set of equations. Also, the interface is very straightforward and user-friendly. The fact that it allows to connect and disconnect “devices” without having to go back to the code and changing variables or adapting the model, makes it very suitable for systems as the ones presented here, where one can add or remove compartments for different kinds of simulations.

## 5.1 Suggestions for future work

- To develop an algorithm for selecting consistent set of initial conditions;
- To study the response of the system in disease cases;
- To implement new routes of drug administration, as shown in Figure 5.1;
- To run simulations for a specific chemical in order to provide quantitative validation;
- To extend the approach for other applications, such as thrombus formation and displacement.



**Figure 5.1:** A flowchart for a more complete coupling as a suggestion for further studies.

# Bibliography

- ABDOLRAZAGHI, M., NAVIDBAKHSI, M., HASSANI, K., 2010, "Mathematical modelling and electrical analog equivalent of the human cardiovascular system", *Cardiovascular Engineering*, v. 10, n. 2, pp. 45–51.
- AMBROSI, D., QUARTERONI, A., ROZZA, G., 2012, *Modeling of physiological flows*, v. 5. Springer Science & Business Media.
- BETTS, J. G., OTHERS, 2013, "Anatomy & physiology", *Open Stax College*.
- BIODIGITAL, 2019. "BioDigital Human". Availability: <<https://human.biodigital.com/index.html>>. Last access on 19/fev/2019.
- BLANCO, P. J., FEIJÓO, R. A., 2011, *Introdução à Modelagem e Simulação Computacional do Sistema Cardiovascular Humano*. Laboratorio Nacional de Computação Cientca (LNCC/MCT).
- BLANCO, P. J., FEIJÓO, R. A., OTHERS, 2010, "A 3D-1D-0D Computational model for the entire cardiovascular system", *Computational Mechanics*, eds. E. Dvorking, M. Goldschmit, M. Storti, v. 29, pp. 5887–5911.
- BROWN, R. P., DELP, M. D., LINDSTEDT, S. L., et al., 1997, "Physiological parameter values for physiologically based pharmacokinetic models", *Toxicology and industrial health*, v. 13, n. 4, pp. 407–484.
- BULANT, C. A., 2017, *Computational models for the geometric and functional assessment of the coronary circulation*. Ph.D. Thesis, National Laboratory for Scientific Computing.
- BURKHOFF, D., ALEXANDER JR, J., SCHIPKE, J., 1988, "Assessment of Windkessel as a model of aortic input impedance", *American Journal of Physiology-Heart and Circulatory Physiology*, v. 255, n. 4, pp. H742–H753.
- CANUTO, D., CHONG, K., BOWLES, C., et al., 2018, "A regulated multiscale closed-loop cardiovascular model, with applications to hemorrhage

and hypertension”, *International journal for numerical methods in biomedical engineering*.

- DEDON, P., TANNENBAUM, S., MURCKO, M., et al., 2013. “20.201 Mechanisms of Drug Actions”. Availability: <MITOpenCourseWarehttps://ocw.mit.edu.License:CreativeCommonsBY-NC-SA.>.
- DI, L., KERNS, E. H., 2015, *Drug-like properties: concepts, structure design and methods from ADME to toxicity optimization*. Academic press.
- DIX, K. J., 2001, “Absorption, distribution, and pharmacokinetics”. In: *Handbook of Pesticide Toxicology (Second Edition)*, Elsevier, pp. 563–582.
- DUANMU, Z., YIN, M., FAN, X., et al., 2018, “A patient-specific lumped-parameter model of coronary circulation”, *Scientific reports*, v. 8, n. 1, pp. 874.
- ETHIER, C. R., 2002, “Computational modeling of mass transfer and links to atherosclerosis”, *Annals of biomedical engineering*, v. 30, n. 4, pp. 461–471.
- FIRESTONE, F. A., 1933, “A new analogy between mechanical and electrical systems”, *The Journal of the Acoustical Society of America*, v. 4, n. 3, pp. 249–267.
- FRANK, O., 1899, “Die grundform des arteriellen pulses”, *Erste Abhandlung Mathematische Analyse Z Biol*, v. 37, pp. 483–526.
- GARFITT, S. J., JONES, K., MASON, H. J., et al., 2002, “Exposure to the organophosphate diazinon: data from a human volunteer study with oral and dermal doses”, *Toxicology letters*, v. 134, n. 1-3, pp. 105–113.
- GUDIÑO, E., SEQUEIRA, A., 2017, “3D mathematical model for blood flow and non-Fickian mass transport by a coronary drug-eluting stent”, *Applied Mathematical Modelling*, v. 46, pp. 161–180.
- HOLANDA, R. W. D., 2015, *Capacitance resistance model in a control systems framework: a tool for describing and controlling waterflooding reservoirs*. Master Thesis, texas a&m university.
- HUBERTS, W., HEINEN, S. G. H., ZONNEBELD, N., et al., 2017, “What is needed to make cardiovascular models suitable for clinical decision support? A viewpoint paper”, *Journal of Computational Science*.

- KAAZEMPUR-MOFRAD, M. R., ETHIER, C. R., 2001, "Mass transport in an anatomically realistic human right coronary artery", *Annals of biomedical engineering*, v. 29, n. 2, pp. 121–127.
- KELM, M., GOUBERGRITS, L., BRUENING, J., et al., 2017, "Model-Based Therapy Planning Allows Prediction of Haemodynamic Outcome after Aortic Valve Replacement", *Scientific reports*, v. 7, n. 1, pp. 9897.
- KERCKHOFFS, R. C. P., NEAL, M. L., GU, Q., et al., 2007, "Coupling of a 3D finite element model of cardiac ventricular mechanics to lumped systems models of the systemic and pulmonic circulation", *Annals of biomedical engineering*, v. 35, n. 1, pp. 1–18.
- KÖPPL, T., SANTIN, G., HAASDONK, B., et al., 2018, "Numerical modelling of a peripheral arterial stenosis using dimensionally reduced models and machine learning techniques", *arXiv preprint arXiv:1802.04628*.
- KUNG, E., PENNATI, G., MIGLIAVACCA, F., et al., 2014, "A simulation protocol for exercise physiology in Fontan patients using a closed loop lumped-parameter model", *Journal of Biomechanical Engineering*, v. 136, n. 8, pp. 081007.
- LIANG, F., LIU, H., 2005, "A closed-loop lumped parameter computational model for human cardiovascular system", *JSME International Journal Series C Mechanical Systems, Machine Elements and Manufacturing*, v. 48, n. 4, pp. 484–493.
- LIANG, F., TAKAGI, S., HIMENO, R., et al., 2009, "Multi-scale modeling of the human cardiovascular system with applications to aortic valvular and arterial stenoses", *Medical & biological engineering & computing*, v. 47, n. 7, pp. 743–755.
- LIU, X., FAN, Y., DENG, X., et al., 2011, "Effect of non-Newtonian and pulsatile blood flow on mass transport in the human aorta", *Journal of biomechanics*, v. 44, n. 6, pp. 1123–1131.
- LUTTRINGER, O., THEIL, F.-P., POULIN, P., et al., 2003, "Physiologically based pharmacokinetic (pbpk) modeling of disposition of epiroprim in humans", *Journal of pharmaceutical sciences*, v. 92, n. 10, pp. 1990–2007.
- MEI, C. C., ZHANG, J., JING, H. X., 2018, "Fluid mechanics of Windkessel effect", *Medical & biological engineering & computing*, pp. 1–10.

- MYNARD, J. P., SMOLICH, J. J., 2015, "One-dimensional haemodynamic modeling and wave dynamics in the entire adult circulation", *Annals of biomedical engineering*, v. 43, n. 6, pp. 1443–1460.
- NICHOLS, W. W., O'ROURKE, M. F., OTHERS, 2005, *McDonald's blood flow in arteries: theoretical, experimental and clinical principles*, v. 340809418. hodder arnold London.
- PARKER, K. H., 2009, "A brief history of arterial wave mechanics", *Medical & biological engineering & computing*, v. 47, n. 2, pp. 111–118.
- PEDLEY, T. J., LUO, X. Y., 1995, *Fluid mechanics of large blood vessels*. Shaanxi People's Press.
- RAPPITSCH, G., PERKTOLD, K., 1996, "Computer simulation of convective diffusion processes in large arteries", *Journal of biomechanics*, v. 29, n. 2, pp. 207–215.
- SHI, Y., LAWFORD, P., HOSE, R., 2011, "Review of zero-D and 1-D models of blood flow in the cardiovascular system", *Biomedical engineering online*, v. 10, n. 1, pp. 33.
- SOARES, R. D. P., SECCHI, A., 2003, "EMSO: A new environment for modelling, simulation and optimisation". In: *Computer Aided Chemical Engineering*, v. 14, Elsevier, pp. 947–952.
- STERGIOPULOS, N., YOUNG, D. F., ROGGE, T. R., 1992, "Computer simulation of arterial flow with applications to arterial and aortic stenoses", *Journal of biomechanics*, v. 25, n. 12, pp. 1477–1488.
- STERGIOPULOS, N., WESTERHOF, B. E., WESTERHOF, N., 1999, "Total arterial inertance as the fourth element of the windkessel model", *American Journal of Physiology-Heart and Circulatory Physiology*, v. 276, n. 1, pp. H81–H88.
- VALENCIA, A., VILLANUEVA, M., 2006, "Unsteady flow and mass transfer in models of stenotic arteries considering fluid-structure interaction", *International Communications in Heat and Mass Transfer*, v. 33, n. 8, pp. 966–975.
- VAN BAKEL, T. M. J., LAU, K. D., HIRSCH-ROMANO, J., et al., 2018, "Patient-Specific Modeling of Hemodynamics: Supporting Surgical Planning in a Fontan Circulation Correction", *Journal of cardiovascular translational research*, pp. 1–11.

- VAN DE VOSSE, F. N., 2003, "Mathematical modelling of the cardiovascular system", *Journal of Engineering Mathematics*, v. 47, n. 3-4, pp. 175–183.
- VAN DE VOSSE, F. N., STERGIOPULOS, N., 2011, "Pulse wave propagation in the arterial tree", *Annual Review of Fluid Mechanics*, v. 43, pp. 467–499.
- VANDEGINSTE, B. G. M., MASSART, D. L., DE JONG, S., et al., 1998, "Handbook of chemometrics and qualimetrics: part b". v. 2, cap. 39 - Pharmacokinetic Models, pp. 449–506, Elsevier.
- WANG, J.-Z., TIE, B., WELKOWITZ, W., et al., 1989, "Incremental network analogue model of the coronary artery", *Medical and Biological Engineering and Computing*, v. 27, n. 4, pp. 416–422.
- WESTERHOF, N., LANKHAAR, J.-W., WESTERHOF, B. E., 2009, "The arterial windkessel", *Medical & biological engineering & computing*, v. 47, n. 2, pp. 131–141.
- WESTERHOF, N., BOSMAN, F., DE VRIES, C. J., et al., 1969, "Analog studies of the human systemic arterial tree", *Journal of biomechanics*, v. 2, n. 2, pp. 121–143.
- WILLEMET, M., CHOWIENCZYK, P., ALASTRUEY, J., 2015, "A database of virtual healthy subjects to assess the accuracy of foot-to-foot pulse wave velocities for estimation of aortic stiffness", *American Journal of Physiology-Heart and Circulatory Physiology*, v. 309, n. 4, pp. H663–H675.
- YOUNG, D. B., 2010, "Control of cardiac output", *Integrated Systems Physiology: From Molecule to Function*, v. 2, n. 1, pp. 1–97.